

FLOOR-EQUIPMENT-PARTS.COM

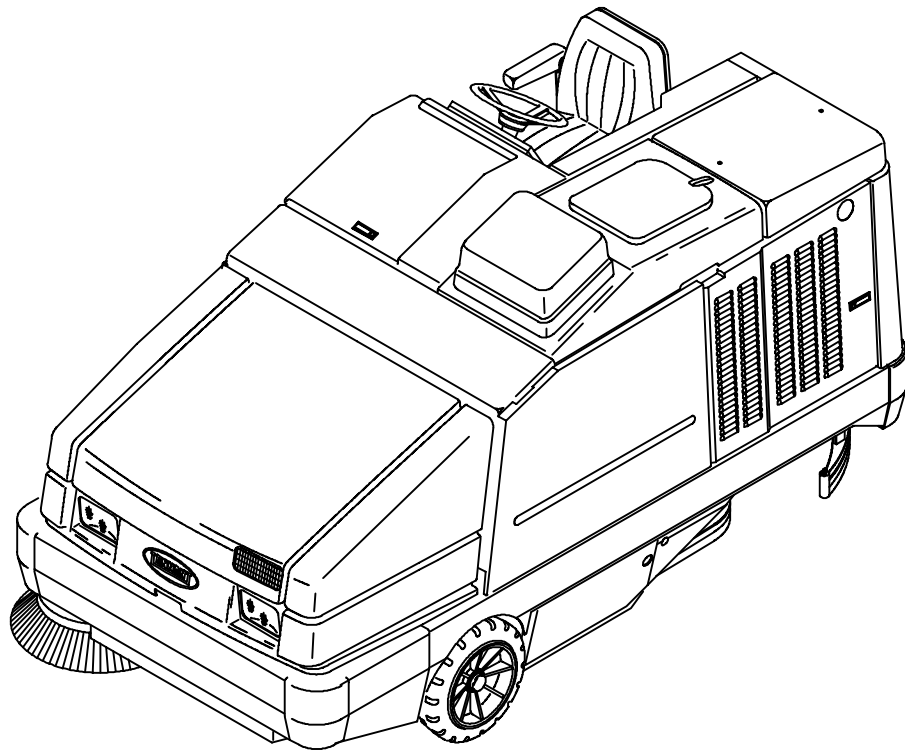

8400

Operator Manual



MM311



This manual is furnished with each new TENNANT Model 8400. It provides necessary operating and preventive maintenance instructions. Read this manual completely and understand the machine before operating or servicing it.

This machine will provide excellent service. However, the best results will be obtained at minimum costs if:

- The machine is operated with reasonable care.
- The machine is maintained regularly – per the maintenance instructions provided.
- The machine is maintained with TENNANT supplied or approved parts.

Manual Number – MM311

Revision: 02

Published: 4-96

CONTENTS

	Page		Page
SAFETY PRECAUTIONS	3	LATCHES	25
OPERATION	7	ENGINE CHOKE KNOB	25
OPERATOR RESPONSIBILITY	7	OPERATOR SEAT	26
MACHINE COMPONENTS	9	HOPPER SUPPORT BAR	26
CONTROL PANEL SYMBOLS	10	HOW THE MACHINE WORKS	27
CONTROLS AND INSTRUMENTS	12	PRE-OPERATION CHECKLIST	27
OPERATION OF CONTROLS	13	CHANGING AN LPG FUEL TANK	29
DIRECTIONAL PEDAL	13	STARTING THE MACHINE	31
BRAKE PEDAL	14	SWEEPING, SCRUBBING, AND BRUSH	
PARKING BRAKE LEVER	14	INFORMATION	33
PARKING BRAKE PEDAL	14	SWEEPING	35
HAZARD LIGHT SWITCH (OPTION) ..	15	STOP SWEEPING	36
OPERATING LIGHTS SWITCH	15	EMPTYING THE HOPPER	37
FILTER SHAKER SWITCH	15	FILLING THE TANKS	38
HOPPER RAISE SWITCH	15	SCRUBBING	40
HOPPER DOOR SWITCH	16	DOUBLE SCRUBBING	42
HOPPER LOWER SWITCH	16	STOP SCRUBBING	42
SIDE BRUSH SWITCH	16	DRAINING AND CLEANING THE TANKS	43
VACUUM FAN SWITCH	16	STOP THE MACHINE	45
MAIN BRUSH NORMAL SPEED		POST-OPERATION CHECKLIST	47
SWITCH	17	ENGAGING HOPPER SUPPORT BAR ..	49
MAIN BRUSH II SPEEDt SWITCH	17	DISENGAGING HOPPER SUPPORT BAR	50
CHARGING SYSTEM LIGHT	17	OPERATION ON INCLINES	51
ENGINE OIL PRESSURE LIGHT	18	OPTIONS	52
ENGINE WATER TEMPERATURE		VACUUM WAND (WET)	52
LIGHT	18	TIE-DOWNS	55
HOPPER TEMPERATURE LIGHT –		MACHINE TROUBLESHOOTING	56
THERMO SENTRY™	18	MAINTENANCE	58
CLOGGED FILTER LIGHT	18	MAINTENANCE CHART	58
RECOVERY TANK FULL LIGHT	19	LUBRICATION	60
FUEL LEVEL GAUGE	19	ENGINE	60
HOURMETER	19	REAR WHEEL SUPPORT	60
ES™ SWITCH (OPTION)	19	FRONT WHEEL BEARINGS	60
DETERGENT FLOW SWITCH		HOPPER LIFT ARM PIVOTS	61
(OPTION)	20	HOPPER DOOR PIVOTS	61
EDGE CLEAN SWITCH	20	REAR SQUEEGEE CASTERS	61
SCRUB BRUSH SWITCH	20	HYDRAULICS	62
SQUEEGEE AND VACUUM		HYDRAULIC FLUID RESERVOIR	62
FAN SWITCH	21	HYDRAULIC FLUID	62
ENGINE SPEED SWITCH	21	HYDRAULIC HOSES	63
STEERING WHEEL	21	PROPELLING MOTOR	63
HORN BUTTON	22	ENGINE	64
IGNITION SWITCH	22	COOLING SYSTEM	64
TURN SIGNAL SWITCH (OPTION) ...	22	AIR FILTER INDICATOR	64
STEERING COLUMN TILT LEVER ...	22	AIR FILTER	65
CIRCUIT BREAKERS	23	FUEL FILTER	66
MAIN BRUSH DOWN PRESSURE		CARBURETOR	66
KNOB	23	SPARK PLUGS	66
SCRUB BRUSH DOWN PRESSURE		DISTRIBUTOR	66
KNOB	24	CRANKCASE VENTILATION SYSTEM	66
SIDE BRUSH DOWN PRESSURE		INTAKE MANIFOLD	66
KNOB	24	TIMING BELT	66
SOLUTION FLOW LEVER	24	BATTERY	67

CONTENTS

	Page		Page
BELTS AND CHAINS	67	SPECIFICATIONS	87
ENGINE BELT	67	GENERAL MACHINE PERFORMANCE ..	87
STATIC DRAG CHAIN	67	POWER TYPE	88
DEBRIS HOPPER	68	STEERING	88
HOPPER DUST FILTER	68	HYDRAULIC SYSTEM	88
REMOVING HOPPER DUST FILTER ..	68	INDEX	89
THERMO SENTRY™	70		
SCRUB HEAD	70		
BRUSHES	70		
MAIN BRUSH	70		
REPLACING MAIN BRUSH	71		
CHECKING AND ADJUSTING MAIN BRUSH PATTERN	72		
SIDE BRUSH	74		
REPLACING SIDE BRUSH	74		
SIDE BRUSH GUARD	75		
SCRUB BRUSHES	75		
REPLACING THE SCRUB BRUSHES	75		
SOLUTION SYSTEM	76		
SOLUTION VALVE	76		
RECOVERY TANK	76		
SOLUTION TANK	76		
SQUEEGEES	77		
LEVELING THE REAR SQUEEGEE ..	77		
ADJUSTING REAR SQUEEGEE BLADE DEFLECTION	78		
SQUEEGEE BLADES	79		
REAR SQUEEGEE	79		
REPLACING OR ROTATING REAR SQUEEGEE BLADES	79		
SIDE SQUEEGEES	80		
REPLACING SIDE SQUEEGEE BLADES	80		
SKIRTS AND SEALS	81		
HOPPER LIP SKIRTS	81		
HOPPER SIDE SKIRT	81		
BRUSH DOOR SKIRTS	81		
REAR SKIRTS	82		
BRUSH DOOR SEALS	82		
HOPPER SEALS	82		
HOPPER INSPECTION DOOR SEAL ..	82		
HOPPER DOOR SEALS	83		
HOPPER COVER SEAL	83		
HOPPER DUST SEAL	83		
HOPPER VACUUM FAN SEAL	83		
DEMISTER AND COVER SEALS	84		
BRAKES AND TIRES	84		
SERVICE BRAKES	84		
PARKING BRAKE	84		
TIRES	84		
REAR WHEEL	84		
PUSHING, TOWING, AND TRANSPORTING THE MACHINE	85		
MACHINE JACKING	86		
STORING MACHINE	86		

SAFETY PRECAUTIONS

The following precautions are used throughout this manual as indicated in their description:



WARNING: To warn of hazards or unsafe practices which could result in severe personal injury or death.

FOR SAFETY: To identify actions which must be followed for safe operation of equipment.

The machine is suited to sweep disposable debris. Do not use the machine other than described in this Operator Manual. The machine is not designed for use on public roads.

The following information signals potentially dangerous conditions to the operator or equipment:

FOR SAFETY:

1. **Do not operate machine:**
 - Unless trained and authorized.
 - Unless operator manual is read and understood.
 - If it is not in proper operating condition.
 - In flammable or explosive areas unless designed for use in those areas.
 - In areas with possible falling objects unless equipped with overhead guard.
2. **Before starting machine:**
 - Check for fuel, oil, and liquid leaks.
 - Keep sparks and open flame away from refueling area.
 - Make sure all safety devices are in place and operate properly.
 - Check brakes and steering for proper operation.
3. **When starting machine:**
 - Keep foot on brake and directional pedal in neutral.
4. **When using machine:**
 - Use brakes to stop machine.
 - Go slow on inclines and slippery surfaces.
 - Use care when reversing machine.
 - Move machine with care when hopper is raised.
 - Make sure adequate clearance is available before raising hopper.
 - Do not carry passengers on machine.
 - Always follow safety and traffic rules.
 - Report machine damage or faulty operation immediately.
5. **Before leaving or servicing machine:**
 - Stop on level surface.
 - Set parking brake.
 - Turn off machine and remove key.
6. **When servicing machine:**
 - Avoid moving parts. Do not wear loose jackets, shirts, or sleeves.
 - Block machine tires before jacking machine up.
 - Jack machine up at designated locations only. Block machine up with jack stands.
 - Use hoist or jack of adequate capacity to lift machine.
 - Wear eye and ear protection when using pressurized air or water.
 - Disconnect battery connections before working on machine.
 - Avoid contact with battery acid.
 - Avoid contact with hot engine coolant.
 - Allow engine to cool.
 - Keep flames and sparks away from fuel system service area. Keep area well ventilated.
 - Use cardboard to locate leaking hydraulic fluid under pressure.
 - Use Tennant supplied or approved replacement parts.

SAFETY PRECAUTIONS

 **WARNING: Engine emits toxic gases. Severe respiratory damage or asphyxiation can result. Provide adequate ventilation. Consult with your regulatory authorities for exposure limits. Keep engine properly tuned.**

 **WARNING: Raised hopper may fall. Engage hopper support bar.**

 **WARNING: Lift arm pinch point. Stay clear of hopper lift arms.**

 **WARNING: Moving belt and fan. Keep away.**

 **WARNING: Flammable materials can cause an explosion or fire. Do not use flammable materials in tank(s).**

 **WARNING: Flammable materials or reactive metals can cause explosion or fire. Do not pick up.**

 **WARNING: Strong vacuum. Keep away from fan inlet when fan is running.**

 **WARNING: Hot bumper. Keep away.**

CALIFORNIA PROPOSITION 65

WARNING: Engine exhaust from this product contains chemicals known to the State of California to cause cancer, birth defects, or other reproductive harm.

The following safety labels are mounted on the machine in the locations indicated. If these or any label becomes damaged or illegible, install a new label in its place.

EMISSIONS LABEL – LOCATED ON THE SIDE PANEL OF THE OPERATOR COMPARTMENT.



ENGINE FAN AND BELT LABEL – LOCATED ON THE RADIATOR SHROUD.



FOR SAFETY LABEL – LOCATED ON THE SIDE PANEL OF THE OPERATOR COMPARTMENT.

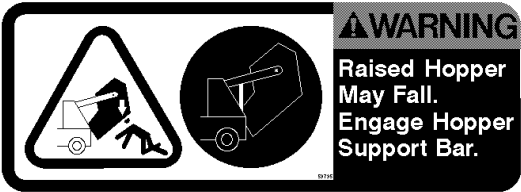
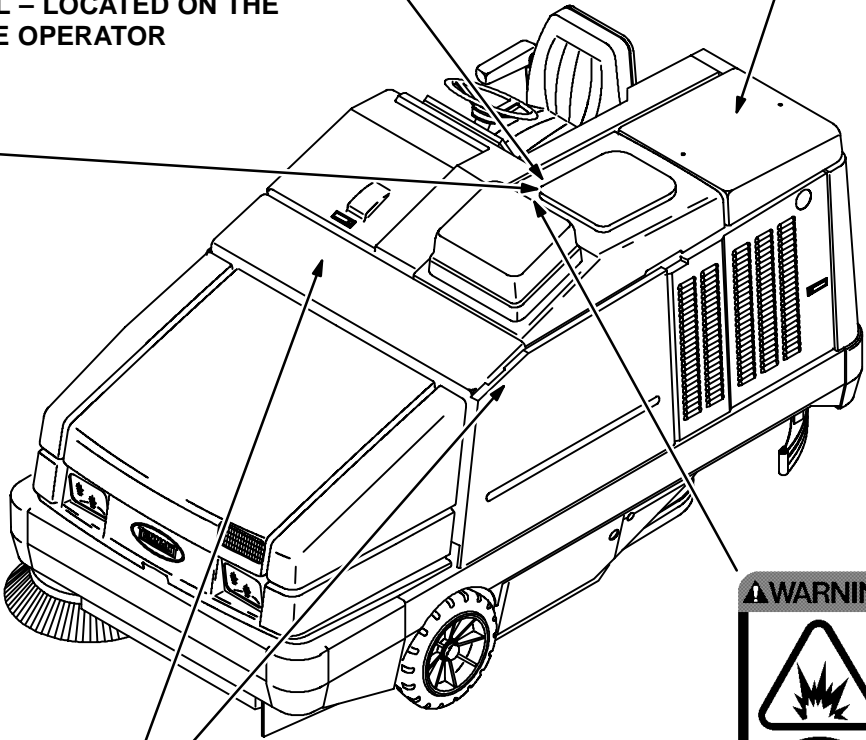

HOPPER SUPPORT BAR LABEL – LOCATED ON THE HOPPER SUPPORT BAR AND ON BOTH HOPPER LIFT ARMS.



FLAMMABLE SPILLS LABEL – LOCATED ON THE SIDE PANEL OF THE OPERATOR COMPARTMENT.

09078

SAFETY PRECAUTIONS

FLAMMABLE MATERIALS LABEL – LOCATED ON THE SOLUTION TANK COVER.

STRONG VACUUM LABEL – LOCATED ON THE VACUUM FAN HOUSING.

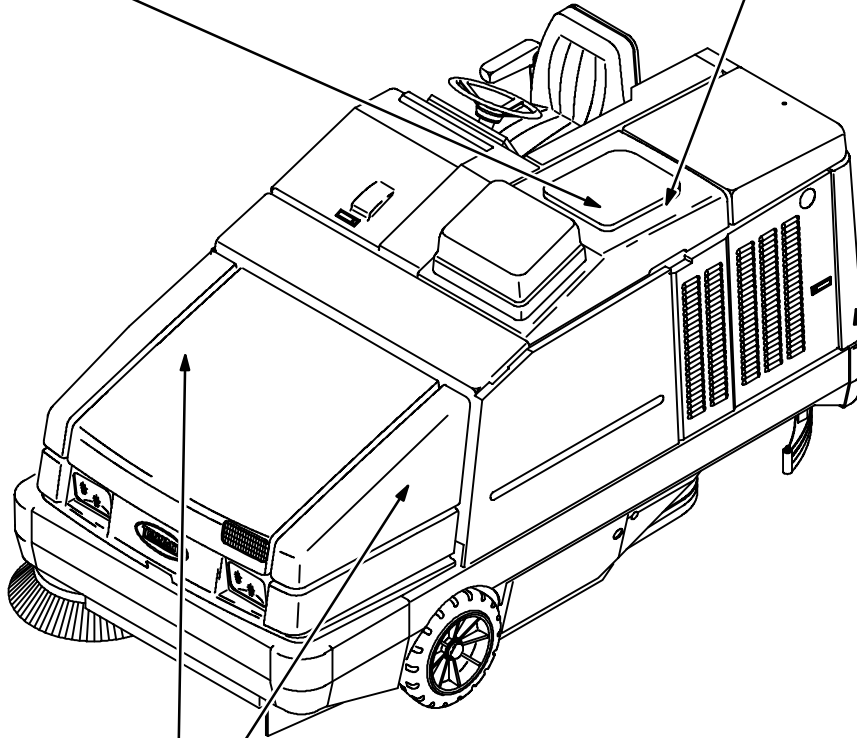
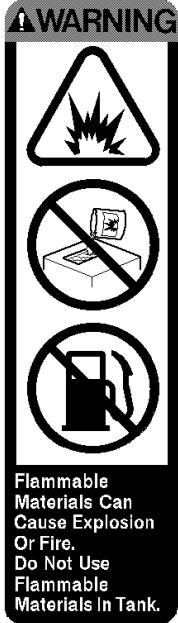

09078



HOPPER LIFT ARMS LABEL – LOCATED ON BOTH HOPPER LIFT ARMS.



HOT BUMPER LABEL – LOCATED ON THE REAR LEFT PANEL.

OPERATION

OPERATOR RESPONSIBILITY

- The operator's responsibility is to take care of the daily maintenance and checkups of the machine to keep it in good working condition. The operator must inform the service mechanic or supervisor when the required maintenance intervals occur as stated in the *MAINTENANCE* section of this manual.
- Read this manual carefully before operating this machine.

FOR SAFETY: Do not operate machine, unless operation manual is read and understood.

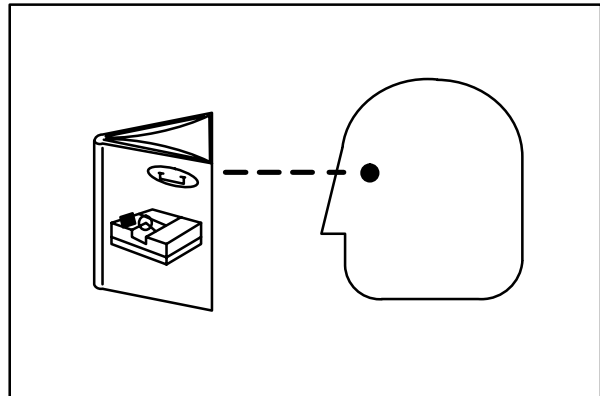

07324

- Check the machine for shipping damage. Check to make sure machine is complete per shipping instructions.
- Check the hydraulic fluid level in the hydraulic reservoir.



- Check the engine oil level.

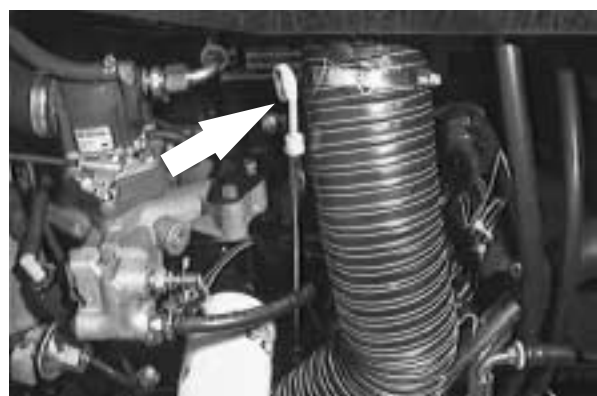

OPERATION

- Check the radiator coolant level.

FOR SAFETY: When servicing machine, avoid contact with hot engine coolant.



- Gasoline powered machines: Fill the fuel tank.

FOR SAFETY: When servicing machine, keep flames and sparks away from fuel system service area. Keep area well ventilated.

- LPG powered machines: Install the LPG fuel tank on the machine. See *CHANGING AN LPG FUEL TANK*.

FOR SAFETY: When servicing machine, keep flames and sparks away from fuel system service area. Keep area well ventilated.

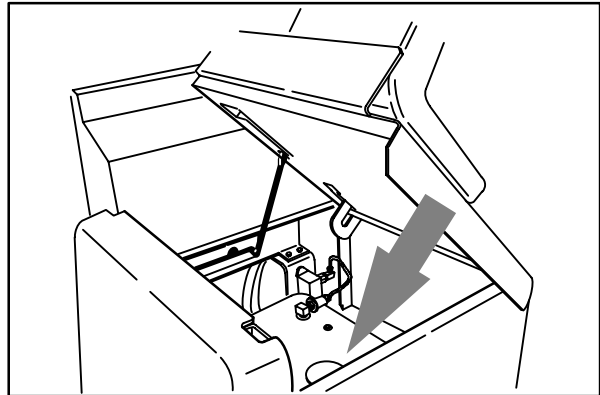

- After the first 50 hours of operation, follow the recommended procedures stated in the *MAINTENANCE CHART*.
- Keep your machine regularly maintained by following the maintenance information in this manual. We recommend taking advantage of a regularly scheduled service contract from your Tennant representative.
- Order parts and supplies directly from your authorized Tennant representative. Use the parts manual provided when ordering parts.

MACHINE COMPONENTS

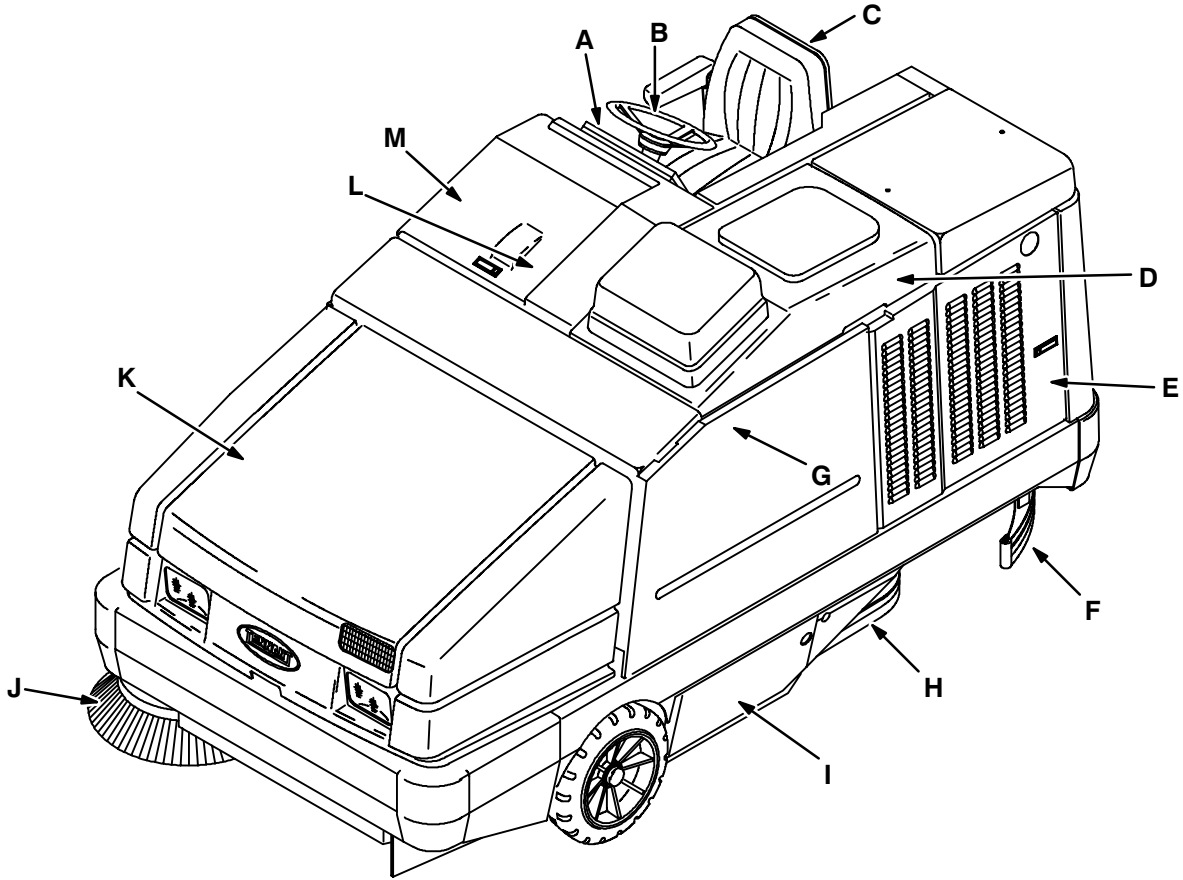

- | | |
|-----------------------------|--------------------------------------|
| A. Instrument Panels | H. Side Squeegee |
| B. Steering Wheel | I. Sweeping Brush Access Door |
| C. Operator Seat | J. Side Brush |
| D. Demister Cover | K. Hopper Cover |
| E. Engine Side Door | L. Recovery Tank |
| F. Rear Squeegee | M. Recovery Tank Cover |
| G. Solution Tank | |

09078

OPERATION

CONTROL PANEL SYMBOLS

These symbols identify controls and displays on the machine:



Hazard Light



Operating Lights



Filter Shaker



Hopper Raise



Hopper Door Close



Hopper Lower



Side Brush Down and On



Fan



Main Brush Down and Normal Speed



Main Brush Down and II Speed™



Charging System



Filter Clogged



Recovery Tank Full



Engine Oil Pressure



Engine Water Temperature



Hopper Temperature – Thermo Sentry™



Fuel



Hourmeter



ES™



Detergent Flow



Scrub brush edge clean



Scrub Brushes Down and On



Rear Squeegee Down and Vacuum On



Engine



Horn



Main Brush Down Pressure Light



Main Brush Down Pressure Heavy



Steering Tilt



Parking Brake



Solution Flow



Scrub Brush Pressure



Side Brush Down Pressure Light



Side Brush Down Pressure Heavy



Circuit Breaker 1



Circuit Breaker 2



Circuit Breaker 3



Circuit Breaker 4



Circuit Breaker 5



Circuit Breaker 6



Circuit Breaker 7



Circuit Breaker 8



Circuit Breaker 9



Variable Flow



Variable Pressure



Gasoline Fuel Only



Hydraulic Fluid Only



Jackpoint

OPERATION

CONTROLS AND INSTRUMENTS

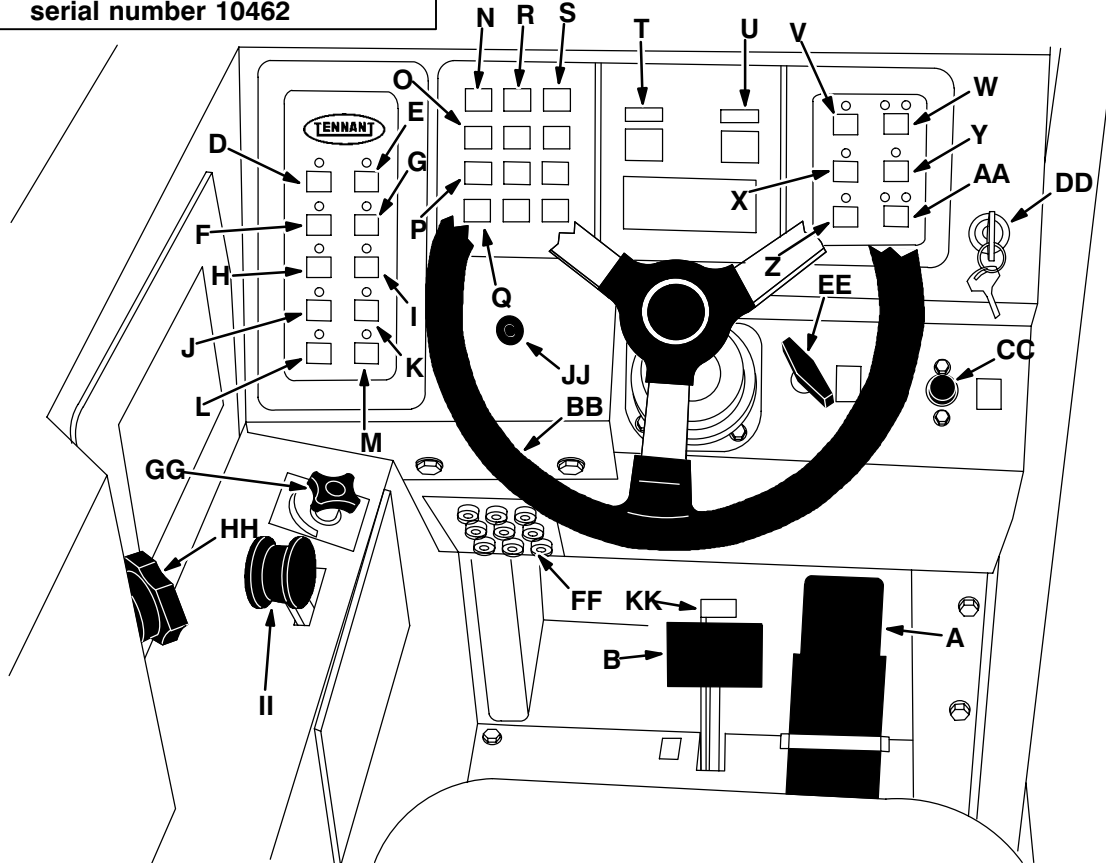
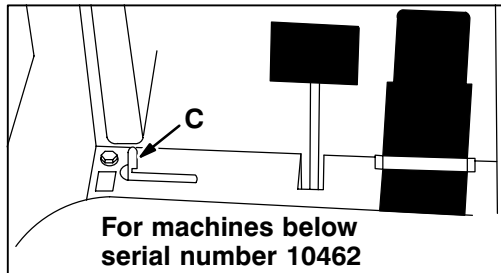

- | | |
|--|------------------------------------|
| A. Directional Pedal | S. Recovery Tank Full Light |
| B. Brake Pedal | T. Fuel Level Gauge |
| C. Parking Brake Lever | U. Hourmeter |
| D. Hazard Light Switch (Option) | V. ES™ Switch (Option) |
| E. Operating Lights Switch | W. Detergent Flow Switch (Option) |
| F. Filter Shaker Switch | X. Edge Clean Switch |
| G. Hopper Raise Switch | Y. Scrub Brush Switch |
| H. Hopper Door Switch | Z. Squeegee and Vacuum Fan Switch |
| I. Hopper Lower Switch | AA. Engine Speed Switch |
| J. Side Brush Switch | BB. Steering Wheel |
| K. Vacuum Fan Switch | CC. Horn Button |
| L. Main Brush Normal Speed Switch | DD. Ignition Switch |
| M. Main Brush II Speed™ Switch | EE. Steering Column Tilt Lever |
| N. Charging System Light | FF. Circuit Breakers |
| O. Engine Oil Pressure Light | GG. Main Brush Down Pressure Knob |
| P. Engine Water Temperature Light | HH. Scrub Brush Down Pressure Knob |
| Q. Hopper Temperature Light – Thermo Sentry™ | II. Solution Flow Lever |
| R. Clogged Filter Light | JJ. Engine Choke Knob |
| | KK. Parking Brake Pedal |

10732

OPERATION OF CONTROLS

DIRECTIONAL PEDAL

The directional pedal controls direction of travel and the propelling speed of the machine. You change the speed of the machine with the pressure of your foot; the harder you press the faster the machine travels.

Forward: Press the top of the directional pedal with the toe of your foot.

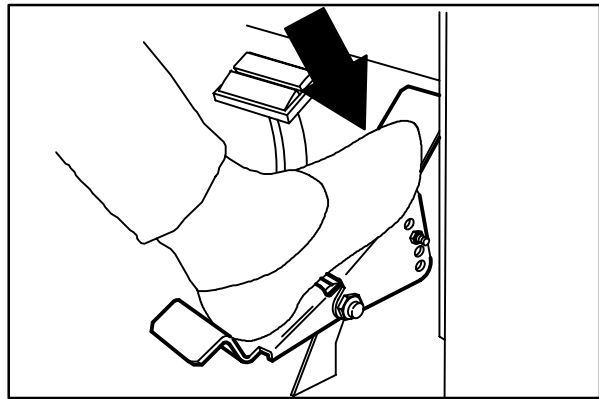

07790

Reverse: Press the bottom of the directional pedal with the heel of your foot.

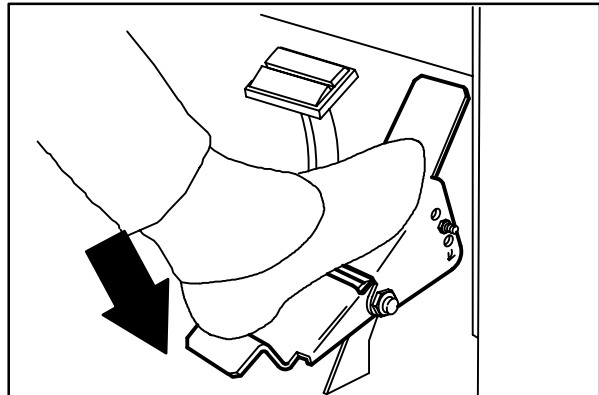

07791

Neutral: Take your foot off the directional pedal and it will return to the neutral position.

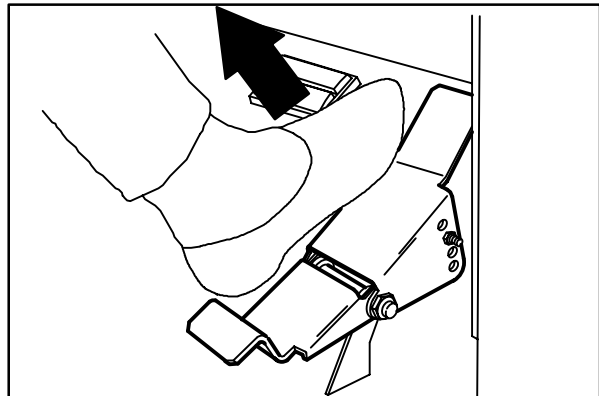

07792

OPERATION

BRAKE PEDAL

The brake pedal stops the machine.

Stop: Take your foot off the directional pedal and let it return to the neutral position. Step on the brake pedal.

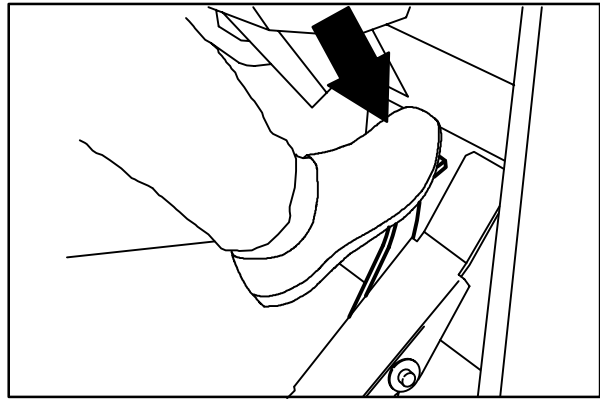

07754

PARKING BRAKE LEVER

The parking brake lever sets and releases the front wheel brakes for machines below serial number 10462.

Set: Move the brake lever from the short to the long slot with your foot. Step on the brake pedal to lock the pedal in place.

FOR SAFETY: Before leaving or servicing machine; stop on level surface, set parking brake, turn off machine and remove key.

Release: Step on the brake pedal to release it, and move the brake lever to the left with your foot at the same time. Lock the lever in place in the short slot.

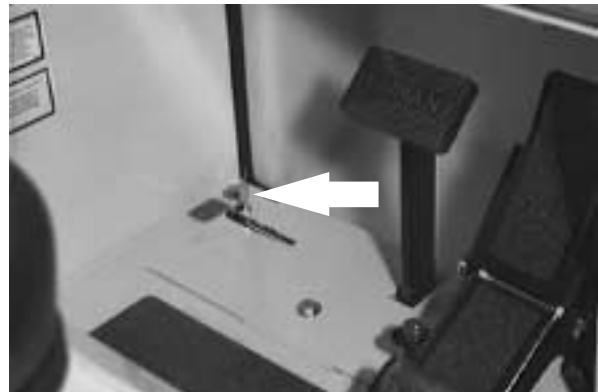

PARKING BRAKE PEDAL

The parking brake pedal sets and releases the rear wheel brakes for machines serial number 10462 and above.

Set: Press on the brake pedal as far as possible, then press on the parking brake pedal with the toe portion of your foot to lock the parking brake pedal in place.

FOR SAFETY: Before leaving or servicing machine; stop on level surface, set parking brake, turn off machine and remove key.

Release: Press on the brake pedal to unlock the parking brake pedal.



HAZARD LIGHT SWITCH (OPTION)

The hazard light switch  powers on and off the hazard light.

On: Press the hazard light switch. The indicator light above the switch will come on.

Off: Press the hazard light switch. The indicator light above the switch will go off.

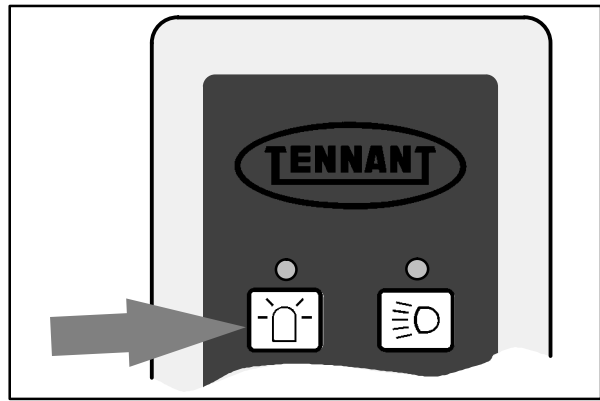

09293

OPERATING LIGHTS SWITCH

The operating lights switch  powers on and off the headlights and taillights.

On: Press the operating lights switch. The indicator light above the switch will come on.

Off: Press the operating lights switch. The indicator light above the switch will go off.

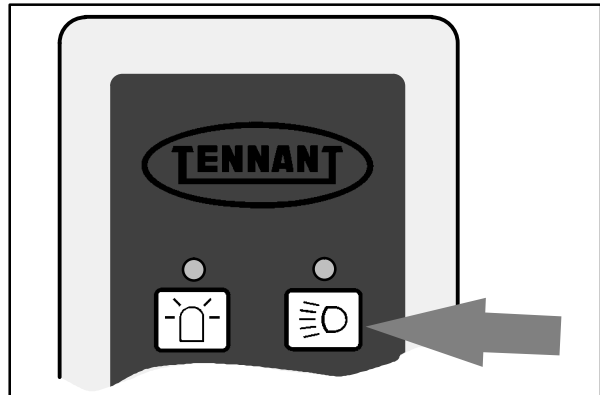

09292

FILTER SHAKER SWITCH

The filter shaker switch  starts the hopper dust filter shaker. The shaker automatically operates for 40 seconds.

Start: Press the filter shaker switch. The indicator light will remain on while the filter shaker is operating.

NOTE: The vacuum fan shuts off while the filter shaker is operating.

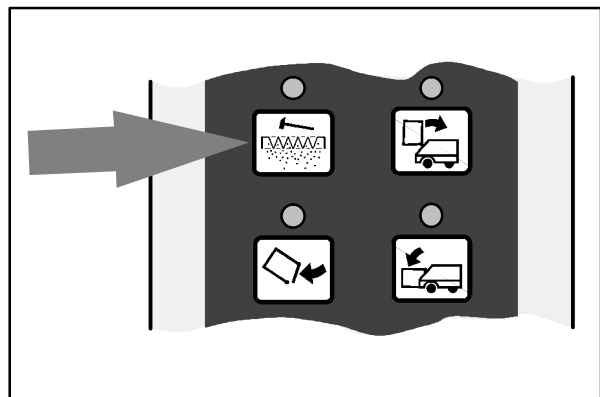

09294

HOPPER RAISE SWITCH

The hopper raise switch  raises the hopper.

Raise: Press and hold the hopper raise switch. The indicator light above the switch will come on.

Hold: Release the hopper raise switch.

 **WARNING: Raised hopper may fall. engage hopper support bar.**

NOTE: The main brush, side brush, and vacuum fan will stop operating when the hopper is raised.

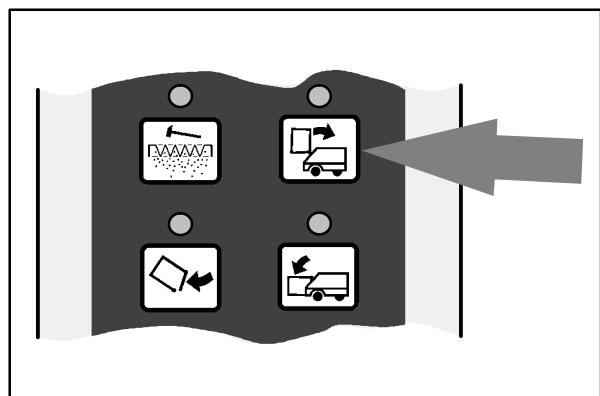

09295

OPERATION

HOPPER DOOR SWITCH

The hopper door switch  opens and closes the hopper door. Close the hopper door when emptying the hopper to control debris and dust.

Open: Press the switch. The indicator light above the switch will go out.

Close: Press the switch. The indicator light above the switch will come on.

NOTE: The hopper door opens automatically when the main brush starts operating, and closes automatically if the main brush is not operating.

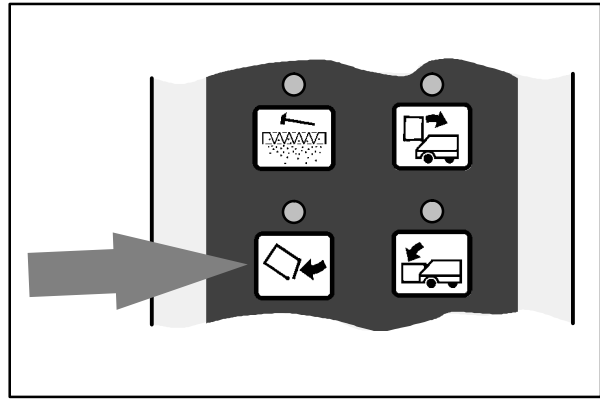

09542

HOPPER LOWER SWITCH

The hopper lower switch  lowers the hopper.

Lower: Press and hold the hopper lower switch. The indicator light above the switch will come on.

Hold: Release the hopper lower switch.

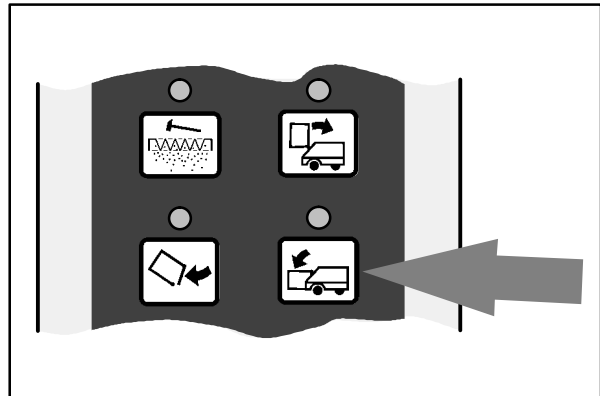

09543

SIDE BRUSH SWITCH

The side brush switch  controls the side brush position and rotation. The main brush must be operating for the side brush to work.

Down and On: Press the switch. The indicator light above the switch will come on.

Up and Off: Press the switch again. The indicator light above the switch will go off.

NOTE: The side brush operates automatically when the main brush starts operating.

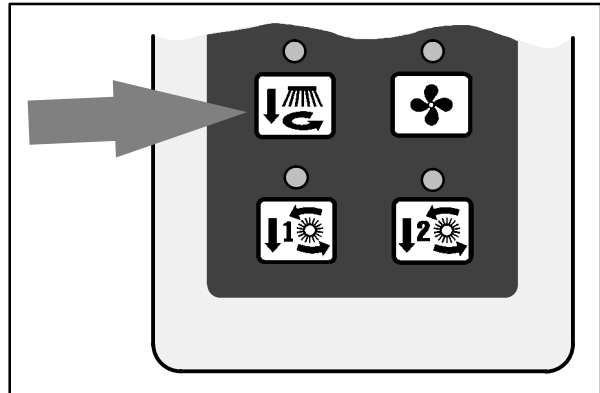

09544

VACUUM FAN SWITCH

The vacuum fan switch  starts and stops the vacuum fan. Do not operate the vacuum fan when sweeping in wet conditions.

Start: Press the switch. The indicator light above the switch will come on.

Stop: Press the switch. The indicator light above the switch will go off.

NOTE: The vacuum fan operates automatically when the main brush starts operating.

NOTE: The vacuum fan will not operate unless the main brush is operating.

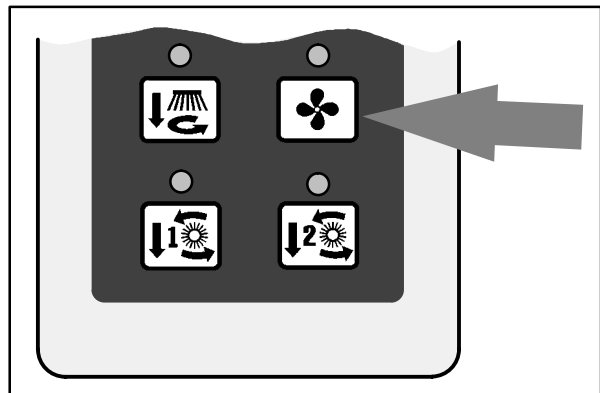

09545

MAIN BRUSH NORMAL SPEED SWITCH

The main brush normal speed switch  controls the main brush position, speed, and rotation. Also the side brush will lower and start, the vacuum fan will come on, the hopper door will open, and the engine speed will increase to (Fast). Normal speed is used for general sweeping.

Down and on: Press the switch. The indicator light above the switch will come on.

Up and off: Press the switch again. The indicator light above the switch will go off.

NOTE: Always raise the main brush when the machine is not being operated for some time. This prevents the main brush from getting a flat spot.

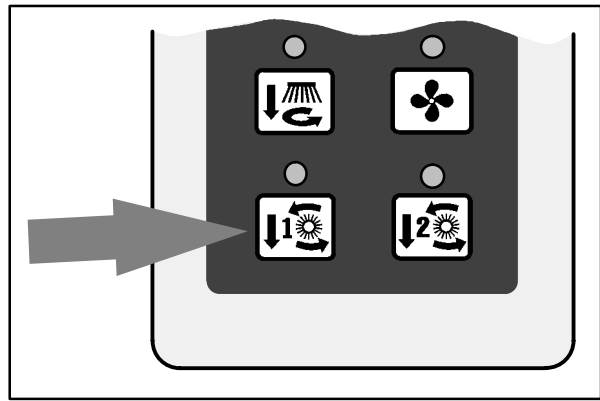

09546

MAIN BRUSH II SPEED™ SWITCH

The main brush II Speed™ switch  controls the main brush position, speed, and rotation. Also the side brush will lower and start, the vacuum fan will come on, the hopper door will open, and the engine speed will increase to (Fast). II Speed™ is used for sweeping light litter.

Down and on: Press the switch. The indicator light above the switch will come on.

Up and off: Press the switch again. The indicator light above the switch will go off.

NOTE: The main brush II Speed™ switch can not be operated while using the scrubbing features. If the II Speed™ is operating when the scrub brushes are started, the machine will automatically change to main brush normal speed.

NOTE: Always raise the main brush when the machine is not being operated for some time. This prevents the main brush from getting a flat spot.

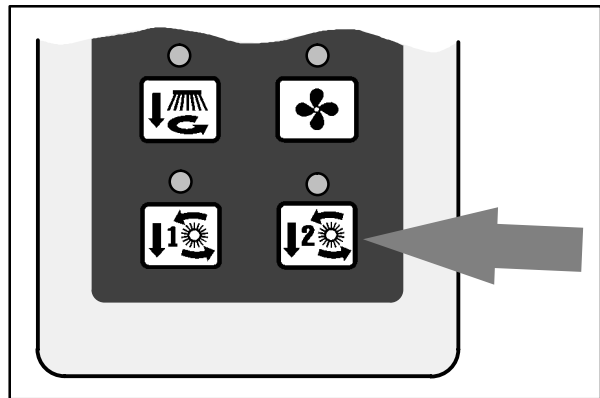

09558

CHARGING SYSTEM LIGHT

The charging system light  comes on when the existing voltage potential of the battery is not within normal range; 10 to 14 Volts. Stop operating the machine. Locate the problem and have it corrected.

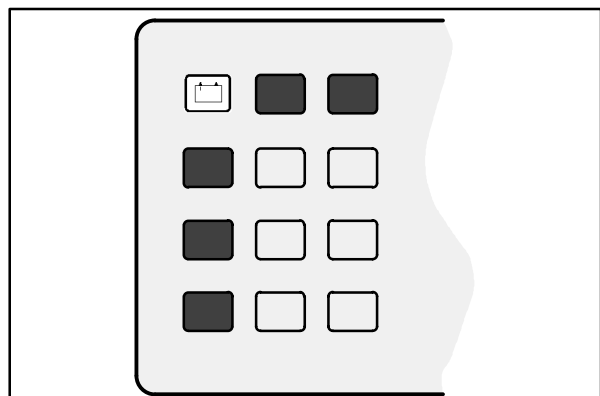

09222

OPERATION

ENGINE OIL PRESSURE LIGHT

The engine oil pressure light  comes on when the engine oil pressure falls below 35 kPa (5 psi). Stop operating the machine. Locate the problem and have it corrected.

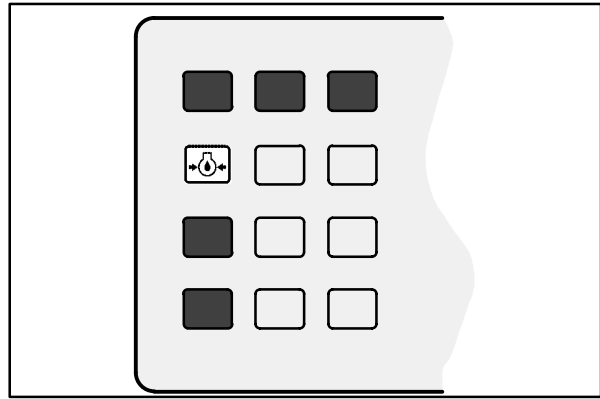

09221

ENGINE WATER TEMPERATURE LIGHT

The engine water temperature light  comes on when the temperature of the engine coolant is more than 107° C (225° F). Stop operating the machine. Locate the problem and have it corrected.

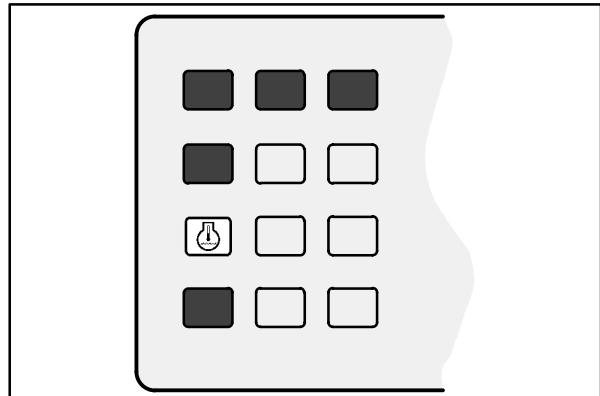

09220

HOPPER TEMPERATURE LIGHT – THERMO SENTRY™

The hopper temperature light  comes on when there is too much heat in the hopper, possibly from a fire. The Thermo Sentry™ will stop the sweeping vacuum fan. Stop operating the machine. Locate the problem and have it corrected.

The Thermo Sentry™ has to be reset manually, see *THERMO SENTRY™* in *MAINTENANCE*.

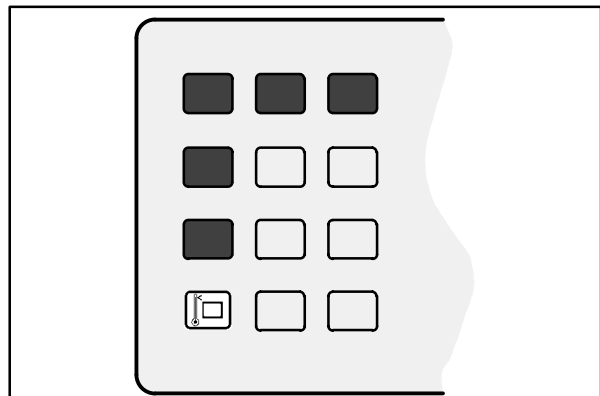

09219

CLOGGED FILTER LIGHT

The clogged filter light  comes on when the hopper dust filter is clogged.

To clean the filter, press the filter shaker switch. If the clogged filter light remains lit, manually clean the hopper dust filter. See *HOPPER DUST FILTER* in *MAINTENANCE*.

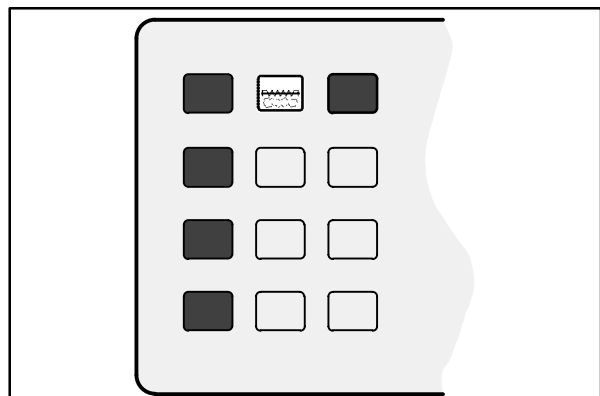

09223

RECOVERY TANK FULL LIGHT

The recovery tank full light  comes on when the recovery tank is full. The rear squeegee will raise and the scrubbing vacuum fan will shut off.

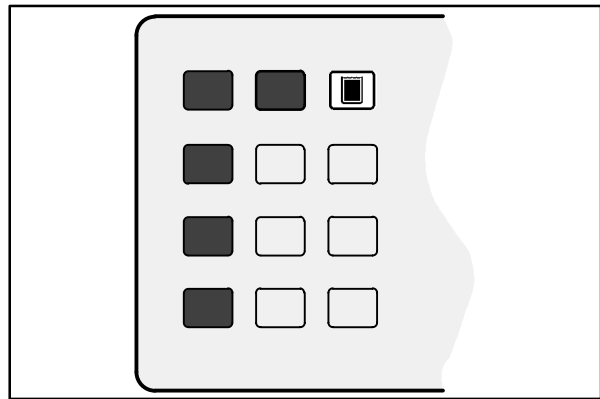

09285

FUEL LEVEL GAUGE

The fuel level gauge  indicates how much fuel is in the fuel tank with a segmented LED light.

Gasoline powered machine: When the tank is full, all ten of the segments are lit. As the fuel tank empties, the segments shut off. The fuel tank is empty when all ten of the segments have shut off.

LPG powered machine: When the tank is full, none of the segments are lit. The last two segments will flash when the tank is low on fuel or empty.

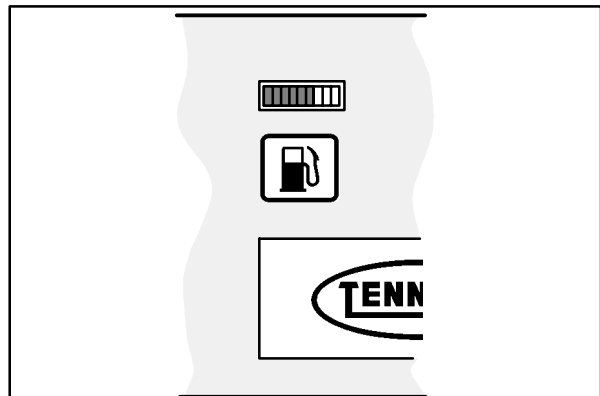

07764

HOURMETER

The hourmeter  records the number of hours the machine has been operated. Use this information to determine machine maintenance intervals.

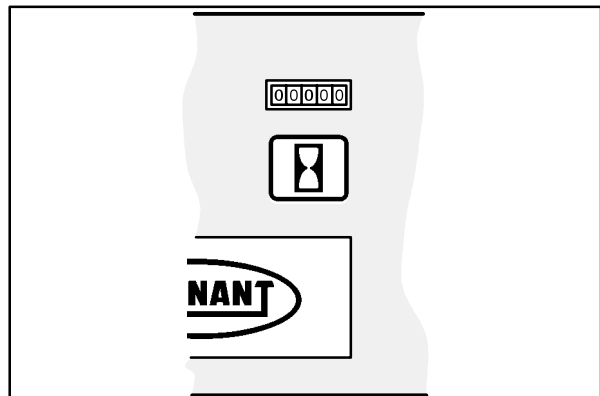

07765

ES™ SWITCH (OPTION)

The ES™ switch  turns on and off the extended scrub system. The ES™ system automatically comes on when the scrub brushes start operating, and will remain on till it is shut off manually.

On: Press the ES™ switch. The indicator light above the switch will come on.

Off: Press the ES™ switch. The indicator light above the switch goes off.

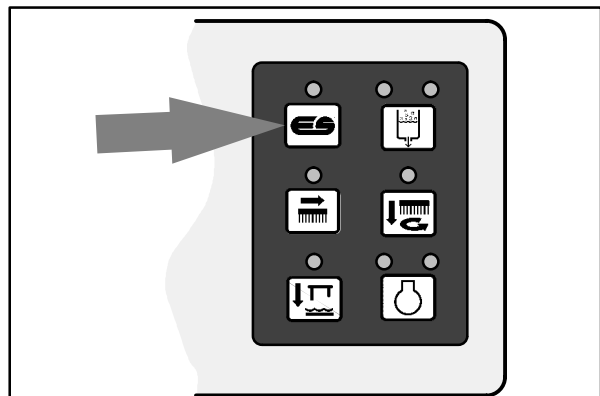

09288

OPERATION

DETERGENT FLOW SWITCH (OPTION)

The detergent flow switch  starts the detergent pump for the ES™ machine.

Start at one-half flow: Press the detergent flow switch. The left indicator light above the switch will come on.

Increase to full flow: Press the detergent flow switch. The right indicator light above the switch will come on.

Stop: Press the detergent switch flow switch. Both indicator lights are off.

NOTE: The detergent pump operates automatically at one-half flow rate when the scrub brush switch and the solution flow lever are used.

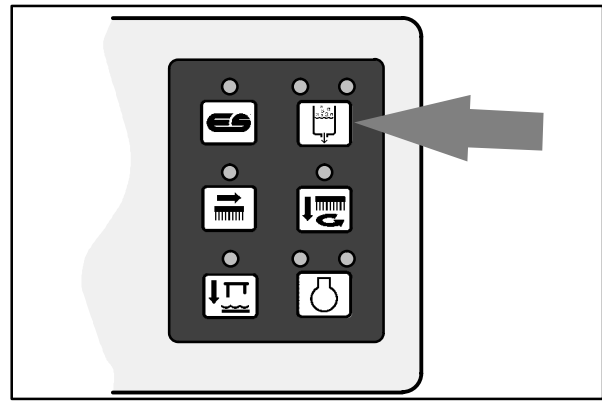

09291

EDGE CLEAN SWITCH

The edge clean switch  extends the scrub head to the right to allow close edge scrubbing.

Out: Press the edge clean switch during normal scrubbing. The indicator light above the switch will come on.

In: Press the edge clean switch. The indicator light above the switch goes off.

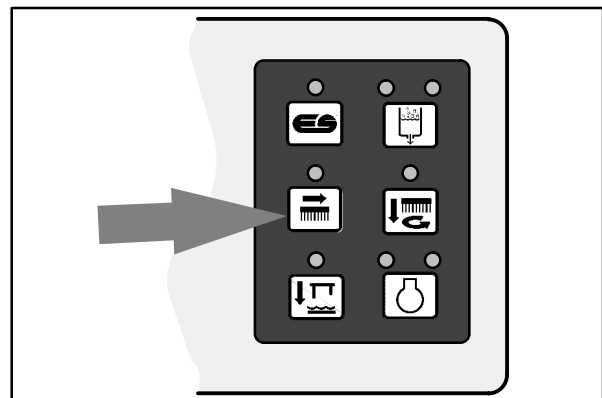

09287

SCRUB BRUSH SWITCH

The scrub brush switch  controls the scrub head position and scrub brush rotation. Also the rear squeegee will lower and the scrubbing vacuum will come on, the optional ES™ system and detergent pump at one-half flow will start, and the engine speed will increase to (Fast). If the main brush II Speed™ is operating when the scrub brushes are started, the machine will automatically change to main brush normal speed.

Down and on: Press the scrub brush switch. The indicator light above the switch will come on.

Up and off: Press the scrub brush switch. The indicator light above the switch goes off.

NOTE: If the II Speed™ is operating when the scrub brushes are started, the machine will automatically change to main brush normal speed.

NOTE: The scrub head will raise when the machine is reversed, or stopped for a short time.

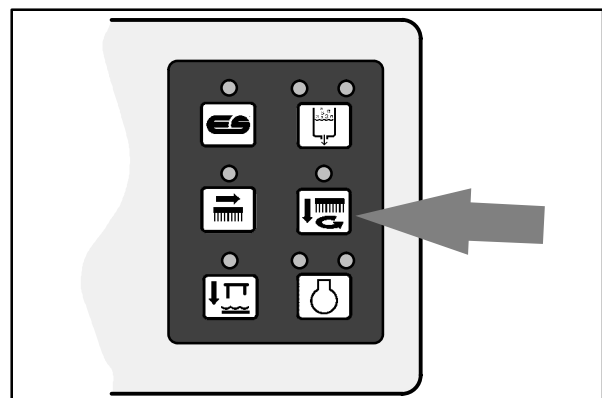

09290

SQUEEGEE AND VACUUM FAN SWITCH

The squeegee and vacuum fan switch  controls the position of the rear squeegee, and starts and stops the scrubbing vacuum fan.

Lower and start: Press the squeegee and vacuum fan switch. The indicator light above the switch will come on.

Raise and stop: Press the squeegee and vacuum fan switch. The indicator light above the switch goes off. There will be a slight delay before the vacuum shuts off.

NOTE: The rear squeegee lowers and scrubbing vacuum starts automatically when the scrub brushes start operating.

NOTE: The squeegee will raise and the vacuum will stop when the machine travels in reverse.

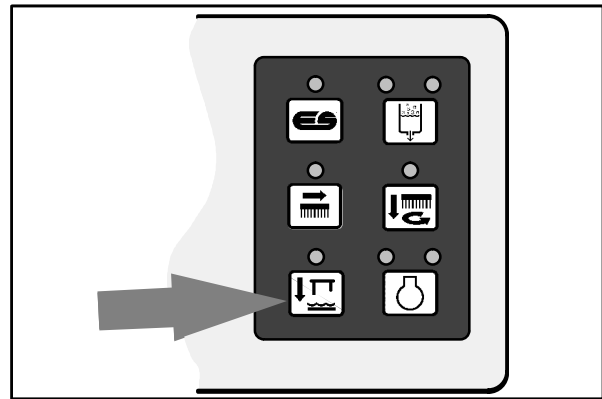

09288

ENGINE SPEED SWITCH

The engine speed switch  controls engine governed speed. The two indicator lights above the switch show the engine speed; Idle or Fast.

Idle: The engine will automatically start in idle speed. To return the engine to idle from another engine speed, press the engine speed switch until the left indicator light comes on.

Fast: Press the engine speed switch and the right indicator light comes on. This speed is for sweeping and scrubbing.

NOTE: The engine will automatically operate in the (Fast) speed when the main brush or scrub brushes start operating.

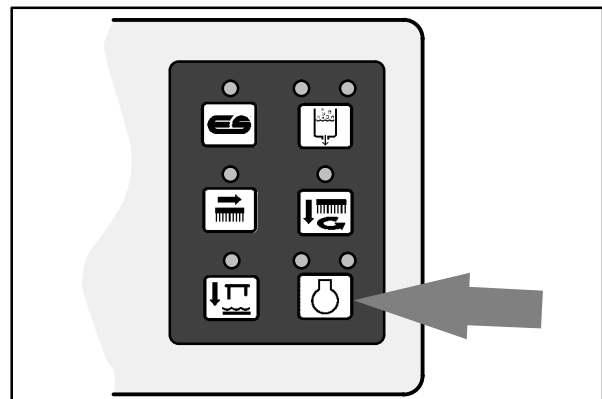

09289

STEERING WHEEL

The steering wheel controls the machine's direction. The machine is very responsive to the steering wheel movements.

Left: Turn the steering wheel to the left.

Right: Turn the steering wheel to the right.

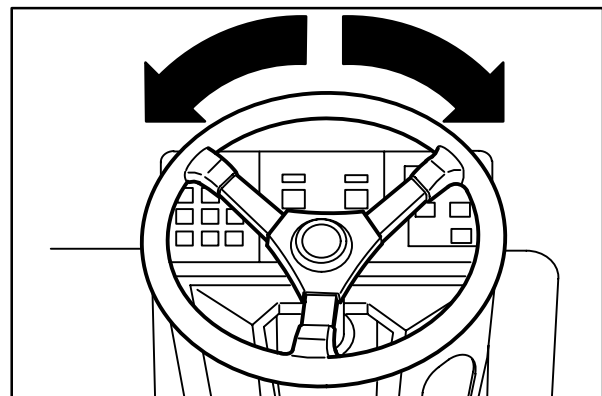

07801

OPERATION

HORN BUTTON

The horn button  operates the horn.

Sound: Press the button.

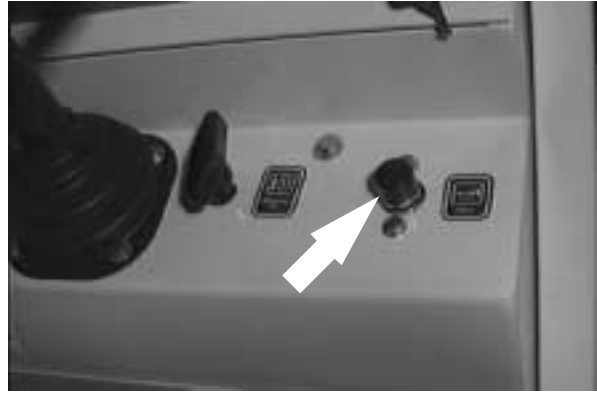

IGNITION SWITCH

The ignition switch starts and stops the engine with a key.

FOR SAFETY: When starting machine, keep foot on brake and directional pedal in neutral.

Start: Turn the key all the way clockwise.
Release the key as soon as the engine starts.

Stop: Turn the key counter-clockwise.



TURN SIGNAL SWITCH (OPTION)

The turn signal switch operates the turn signals.

Right: Push the switch lever forward.

Left: Pull the switch lever back.

Flashers: Pull out the knob.

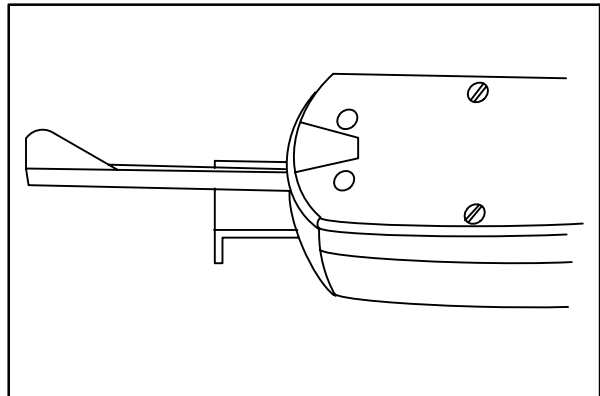

06745

STEERING COLUMN TILT LEVER

The steering wheel tilt lever  controls the angle of the steering wheel.

Adjust: Pull out the tilt lever, move the wheel up or down, and release the tilt lever.

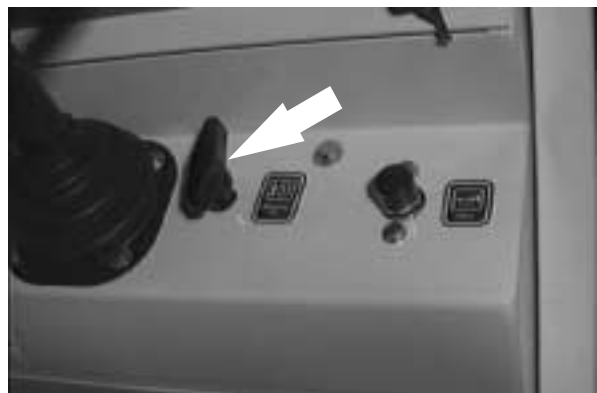

CIRCUIT BREAKERS









The circuit breakers are resettable electrical circuit protection devices. Their design stops the flow of current in the event of a circuit overload. Once a circuit breaker is tripped, it must be reset manually. Press the reset button after the breaker has cooled down.

If the overload that caused the circuit breaker to trip is still there, the circuit breaker will continue to stop current flow until the problem is corrected.

The circuit breakers are located in the operator compartment.

The chart lists the circuit breakers and the electrical components they protect.



Circuit Breaker	Rating	Circuit Protected
 CB-1	15 A	Ignition
 CB-2	15 A	Filter shaker, vacuum fan
 CB-3	15 A	Operating lights
 CB-4	15 A	Scrubbing
 CB-5	15 A	Horn
 CB-6	10 A	Instrument panel
 CB-7	15 A	Sweeping
 CB-8	15 A	Hazard light
 CB-9	15 A	ES™

MAIN BRUSH DOWN PRESSURE KNOB

The main brush down pressure knob changes the amount of contact the main brush has with the sweeping surface.

 Heavy: Turn the main brush down pressure knob counter-clockwise.

 Light: Turn the main brush down pressure knob clockwise.



OPERATION

SCRUB BRUSH DOWN PRESSURE KNOB

The scrub brush down pressure knob changes the pressure of contact the scrub brushes have with the scrubbing surface.

Increase: Turn the scrub brush down pressure knob clockwise.

Decrease: Turn the scrub brush down pressure knob counter-clockwise.

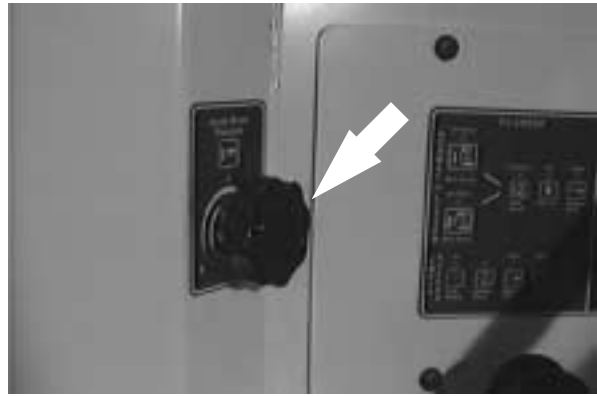

SIDE BRUSH DOWN PRESSURE KNOB

The side brush down pressure knob changes the side brush contact with the sweeping surface.

 Heavy: Turn the side brush down pressure knob counter-clockwise.

 Light: Turn the side brush down pressure knob clockwise.



SOLUTION FLOW LEVER

The solution flow lever  controls the flow of solution to the floor.

Start: Push the lever forward. To increase the solution flow, continue pushing the lever forward.

Stop: Pull the lever all the way back.

ES™ mode: The solution lever also starts and stops the detergent pump.



LATCHES

The side doors, engine cover, seat access cover, and recovery tank cover are secured with latches.

Open the main brush side doors: Push down on the door latch.

Open the engine side door: Push in the door latch.

Open the demister cover: Push in on the cover latch.

Open the recovery tank cover: Push in the cover latch.

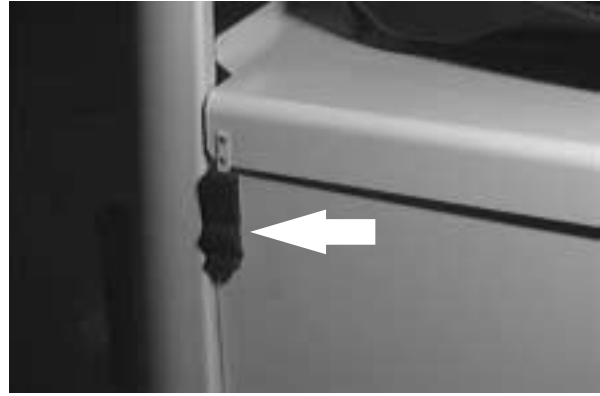
**ENGINE CHOKE KNOB**

The engine choke knob controls the engine choke on gasoline powered machines.

On: For cold starting, pull the engine choke knob out.

Off: Push the engine choke knob in.

OPERATION

OPERATOR SEAT

The operator seat is a fixed back style with a forward-backward adjustment.

Adjust: Pull the lever out, slide the seat backward or forward to the desired position and release the lever.

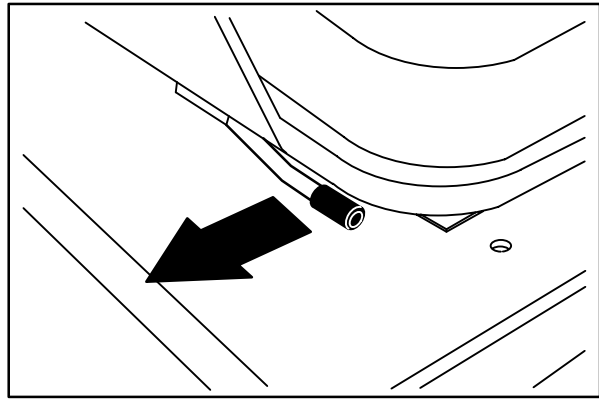

07797

Lift: Pull up on the seat mounting plate until the seat mount locks up.

Lower: Pull on the release lever and lower the seat mounting plate.

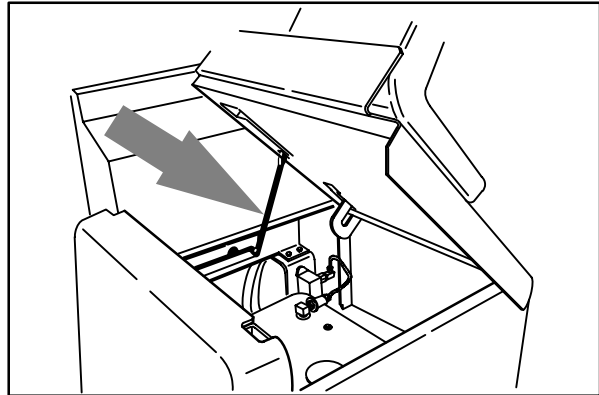

08052

HOPPER SUPPORT BAR

The hopper support bar is located on the operator's side of the hopper. The hopper support bar holds the hopper in the raised position to allow work under the hopper. **DO NOT** rely on the machine hydraulic system to keep the hopper raised.



**WARNING: Raised hopper may fall.
Engage hopper support bar.**

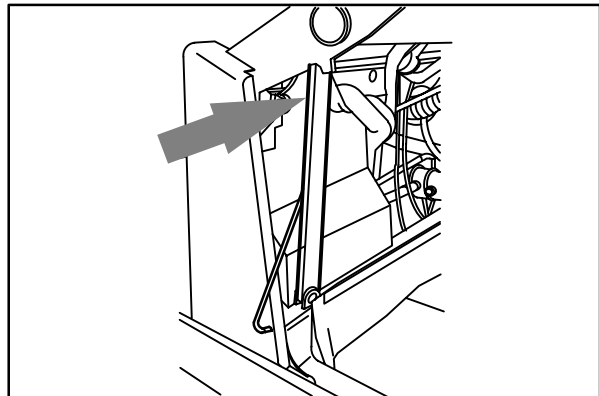

07803

HOW THE MACHINE WORKS

The steering wheel controls the direction of machine travel. The directional pedal controls the speed and forward/reverse direction. The brake pedal slows and stops the machine.

The side brush sweeps debris into the path of the main sweeping brush. The main brush sweeps debris from the floor into the hopper. The vacuum system pulls dust and air through the hopper and the hopper dust filter.

Water and detergent from the solution tank flows to the floor through a solution valve to the scrub brushes. The brushes scrub the floor. As the machine is moved forward the squeegee wipes the dirty solution off the floor, which is then picked up and drawn into the recovery tank.

When using the ES™ mode, the dirty solution in the recovery tank is filtered and returned to the solution tank to be reused.

When sweeping and scrubbing is finished, clean the hopper dust filter, empty the hopper, and drain and clean the recovery tank. If using the ES™ system, drain and clean the solution tank, and clean the ES™ filter.

PRE-OPERATION CHECKLIST

- Check under the machine for leaks (fuel, oil, coolant, scrubbing solution).

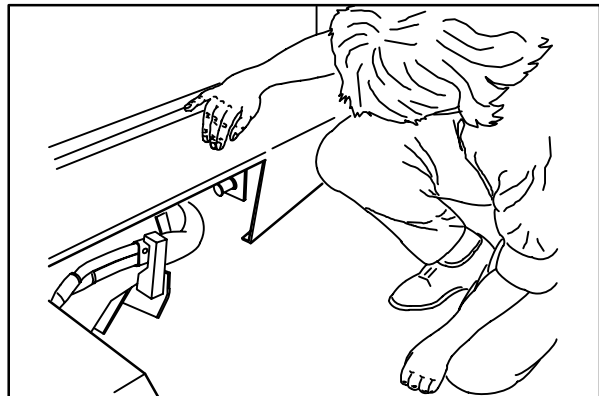

07807

OPERATION

- Check the engine air filter indicator.



- Check the engine oil level.



- Check fuel level.

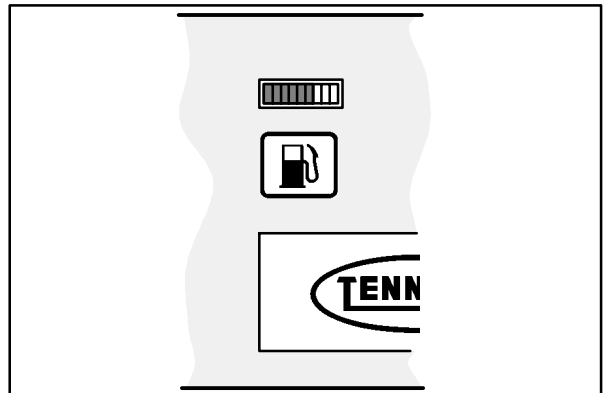

07764

- Check the brakes and steering for proper operation.

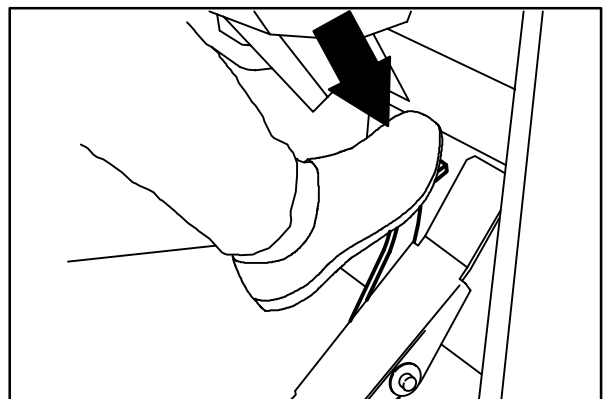

07754

- ❑ Check the rear squeegee for wear and proper deflection. Check the side squeegees for wear.



CHANGING AN LPG FUEL TANK

1. Park the machine in a designated safe area.
2. Close the tank service valve on the LPG tank located under the operator seat.
3. Operate the engine until it stops from lack of fuel, then set the machine parking brake.

FOR SAFETY: When servicing machine, Keep flames and sparks away from fuel system service area. Keep area well ventilated.

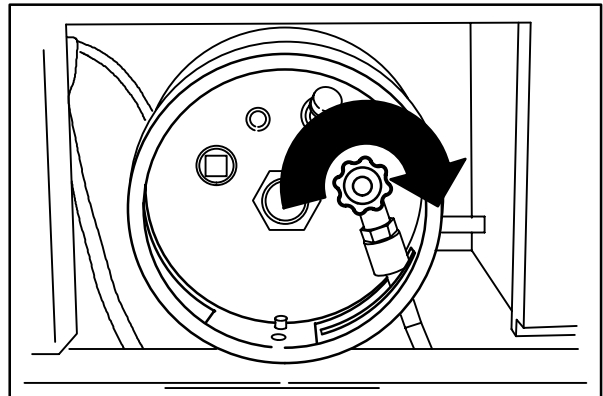

07810

4. Put on gloves and remove the quick-disconnect tank coupling.
5. Unlatch and remove the empty LPG fuel tank from the machine and store the tank in a designated, safe area.

NOTE: Make sure the LPG fuel tank matches the fuel system (liquid tank with liquid system).

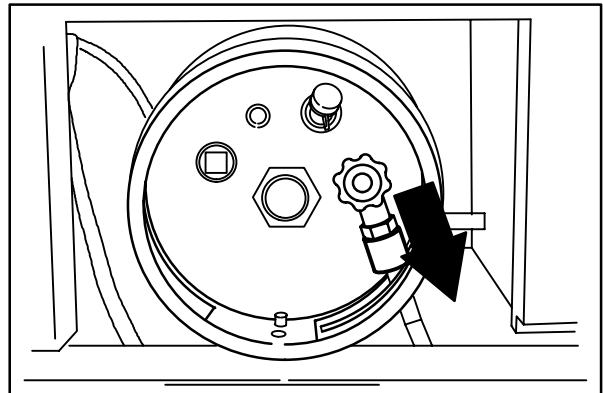

07811

6. Carefully put the filled LPG tank in the machine so that the tank centering pin enters the aligning hole in the tank collar.
7. Fasten the tank hold-down clamp to lock the tank in position.

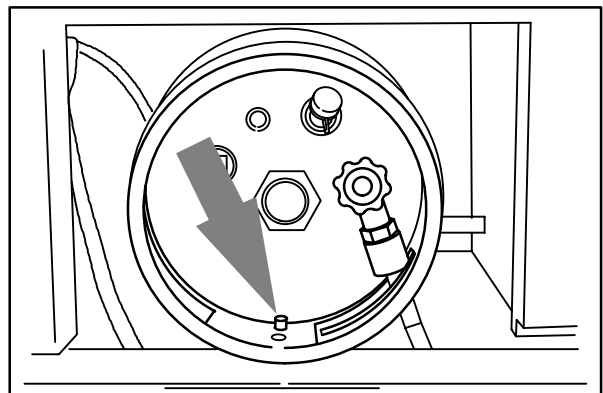

07812

OPERATION

8. Connect the LPG fuel line to the tank service coupling. Make sure the service coupling is clean and free of damage. Also make sure it matches the machine service coupling.

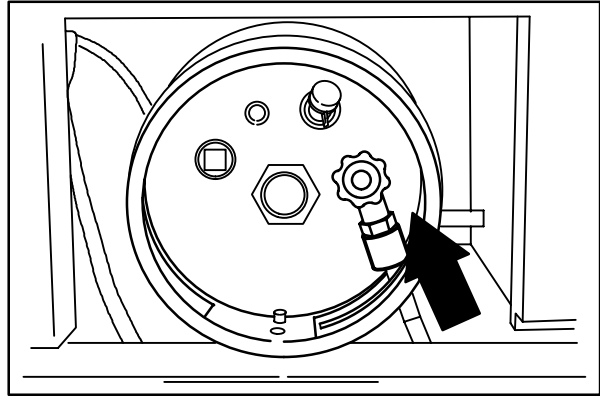

07813

9. Open the tank service valve slowly and check for leaks. Close the service valve immediately if an LPG leak is found, and tell the appropriate personnel.

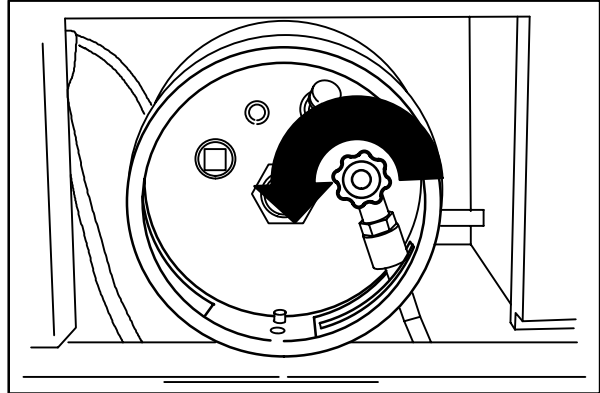

07814

STARTING THE MACHINE

1. LPG powered machines: Open the liquid service valve slowly.

NOTE: Opening the service valve too quickly may cause the service check valve to stop the flow of LPG fuel. If the check valve stops the fuel flow, close the service valve, wait a few seconds and open the valve slowly again.

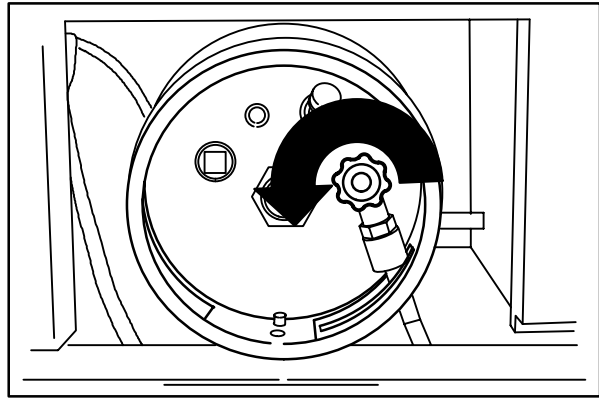

07814

2. You must be in the operator's seat with the directional pedal in neutral, and your foot on the brake pedal or with the parking brake set.

FOR SAFETY: When starting machine, keep foot on brake and directional pedal in neutral.



3. Gasoline powered machines: Pull out the choke knob when the engine is cold. Push in the choke knob after the engine is running smoothly.

LPG powered machines: When the engine is cold and exposed to cold temperatures; open the engine cover, press the primer button on the LPG vaporizer, and close the engine cover.

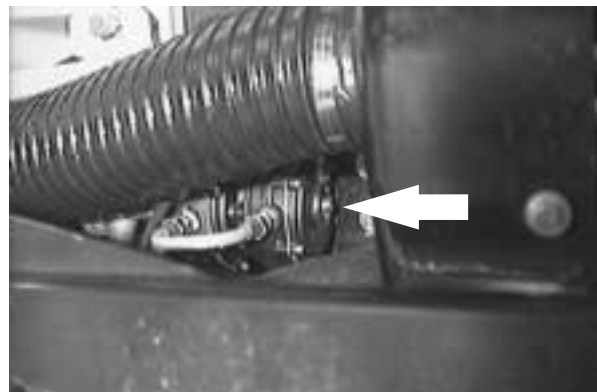

OPERATION

4. Turn the ignition switch key clockwise until the engine starts.

NOTE: Do not operate the starter motor for more than 10 seconds at a time or after the engine has started. Allow the starter to cool between starting attempts or damage to the starter motor may occur.

5. Allow the engine and hydraulic system to warm up three to five minutes.

⚠ WARNING: Engine emits toxic gases. Severe respiratory damage or asphyxiation can result. Provide adequate ventilation. Consult with your regulatory authorities for exposure limits. Keep engine properly tuned.

6. Release the machine parking brake.

7. Select the (Fast) engine speed with the engine speed switch.

8. Drive the machine to the area being swept.

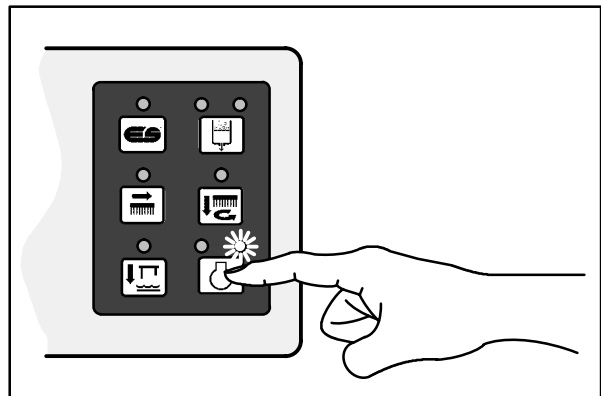

09560

SWEEPING, SCRUBBING, AND BRUSH INFORMATION

Pick up oversized debris before sweeping. Flatten or remove bulky cartons from aisles before sweeping. Pick up pieces of wire, twine, string, etc., which could become entangled in brush or brush plugs.

Plan the sweeping and scrubbing in advance. Try to arrange long runs with minimum stopping and starting. Sweep debris from very narrow aisles into main aisles ahead of time. Do an entire floor or section at one time. Drive as straight a path as possible. Avoid bumping into posts or scraping the sides of the machine. Overlap the brush paths.

Avoid turning the steering wheel too sharply when the machine is in motion. The machine is very responsive to the movement of the steering wheel. Avoid sudden turns, except in emergencies.

Adjust the machine speed, scrub brush pressure, and detergent and solution flow as required when scrubbing. Use minimum scrub brush pressure and solution flow required for the best scrubbing results. The machine has an edge clean feature for scrubbing against an edge.

When the recovery tank is almost full, the recovery tank full indicator will light. The recovery tank will have to be drained and cleaned. Then refill the solution tank with clean water and detergent and continue cleaning.

For best results, use the correct brush type for your sweeping and scrubbing application. The following are recommendations for main sweeping, scrubbing, and side brush applications.

Nylon 5-double and 8-double Row Main Brush

– Recommended for general sweeping, and has good hopper loading. Nylon has the longest life of the bristle types. Use this brush for sweeping rough or irregular surfaces.

Nylon 24-row Main Brush – Recommended for severe dust conditions on rough surfaces. This brush has excellent pickup and long life.

Polypropylene 8-double Row Main Brush –

Superior pick-up of sand, gravel, and paper litter. Polypropylene retains its stiffness when wet, and can be used indoors or out with equal performance. Not recommended for high-temperature debris.

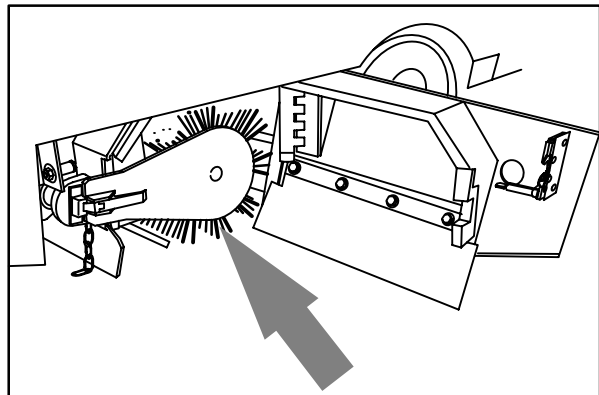

08002

OPERATION

Polypropylene and Wire 8-double Row Main Brush – The wire bristles loosen slightly packed soilage and heavier debris. The polypropylene bristles sweep up the debris with excellent hopper loading.

Fiber and Wire 24-row Main Brush – Offers good sweeping action and pickup in heavy dust concentrations. This brush is recommended where soilage is slightly encrusted. The brush is not recommended for heavy buildup or hard packed soilage.

Wire 8-double Row Main Brush – The stiff wire bristles cut through compacted grime, hard to sweep dirt, and dirt mixed with oil, grease, or mud. This brush is recommended for foundry sweeping where heat may melt synthetic bristles. This brush has good hopper loading ability, but is not recommended for dusty applications.

Polypropylene Side Brush – A good general purpose brush for sweeping of light to medium debris in both indoor and outdoor applications. This brush is recommended when bristles may get wet.

Nylon Side Brush – A longer life, general purpose brush that is recommended for rough surfaces.

Flat Wire Side Brush – Recommended for outside and curb-side sweeping where soilage is heavy or compacted. The stiff wire bristles dig out soilage. This brush is also recommended for foundry sweeping where heat may melt synthetic bristles.

Polypropylene Scrub Brush – A general-purpose brush with stiff bristles for aggressive action on slightly compacted soilage. Works well on concrete, wood, and tile surfaces.

Wire Scrub Brush – This brush is the most aggressive. Recommended for soilage, heavy buildup and stripping rubber burns.

Non-scuff Polypropylene Scrub Brush – This brush uses a softer, general purpose poly bristle to lift lightly compacted soilage, without scuffing high-gloss coated floors.

Nylon Scrub Brush – Recommended for scrubbing coated floors. Cleans without scuffing.

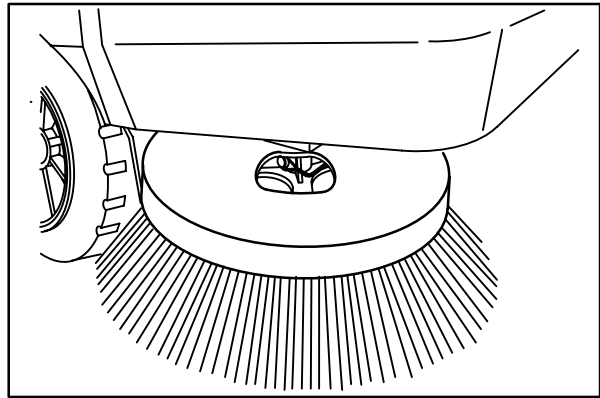

08046



Super Abrasive Bristle Scrub Brush – Nylon fiber impregnated with abrasive grit to remove stains and soilage. Strong action on any surface, performing well on buildup, grease, or rubber burns.

Bassine Scrub Brush – Traditional natural fiber is still preferred by many for general scrubbing on quarry tile, terrazzo, and marble.

Stripping Pad – This pad is for stripping floors. Quickly and easily cuts through old finish to prepare the floor for recoating.

Scrubbing Pad – This pad is for scrubbing floors. Removes dirt, spills and scuffs, leaving a clean surface ready for recoating.

Buffing Pad – This pad is for buffing floors. Quickly cleans and removes scuff marks while polishing the floor to a high gloss.

Polishing Pad – This pad is for polishing floors. Maintains a high gloss. Use to buff very soft finishes and lower traffic areas, or use for polishing soft waxes on wood floors.

SWEEPING

1. Start the engine.



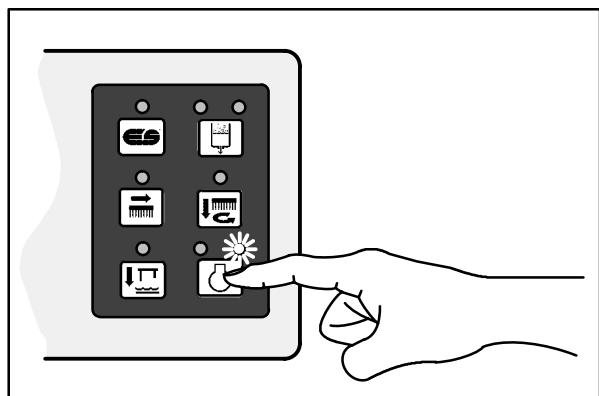

2. Select the (Fast) engine speed with the engine speed switch.



09560

OPERATION

3. Press the main brush normal switch  for normal sweeping, or main brush II Speed™ switch  for sweeping light litter.

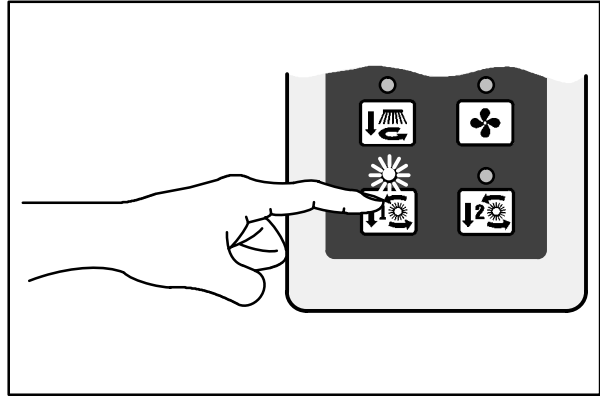

The side brush will automatically lower and start, the sweeping vacuum will start, the hopper door will open, and engine speed will change to (Fast).

4. Sweep as needed.



09561

STOP SWEEPING

1. Press the main brush normal switch , or main brush II Speed™ switch  to raise and stop the main brush.

The side brush will automatically stop and raise, the sweeping vacuum will stop, the hopper door will close, the engine speed will remain at (Fast).

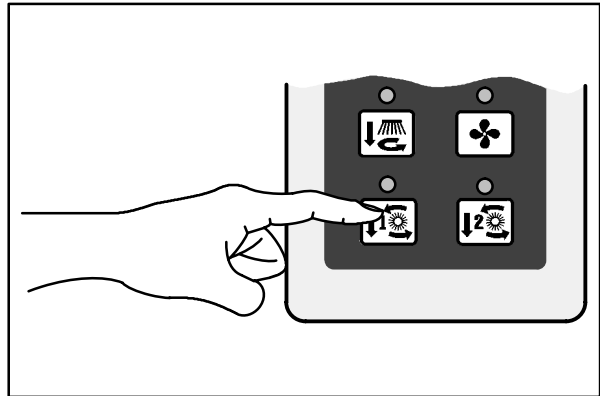

09564

2. Press the filter shaker switch  to shake the hopper dust filter.

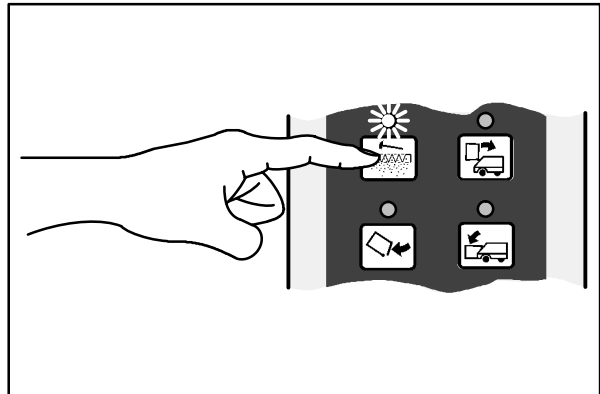

09567

EMPTYING THE HOPPER

1. Slowly drive the machine to the debris site or debris container.
2. Make sure the indicator light above the hopper door switch is on to show the hopper door is closed. If not, press the hopper door switch.

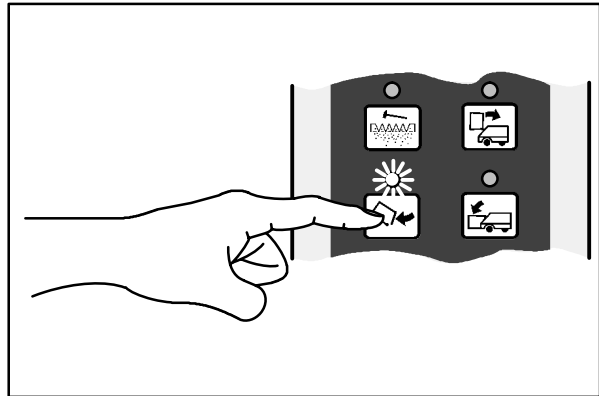

09568

3. Press and hold the hopper raise switch  to raise the hopper to the desired height.

FOR SAFETY: When using machine, make sure adequate clearance is available before raising hopper.

NOTE: Be aware that the minimum ceiling height needed to high dump the hopper is 2490 mm (98 in).

FOR SAFETY: When using machine, move machine with care when hopper is raised.

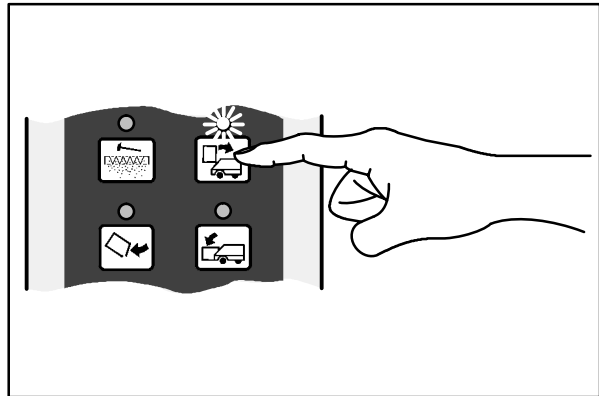

09569

4. Drive the machine up to the debris container.
5. Push the hopper door switch  to open the hopper door. The indicator light above the switch goes out.
6. Slowly back the machine away from the debris site or debris container.

FOR SAFETY: When using machine, use care when reversing machine.

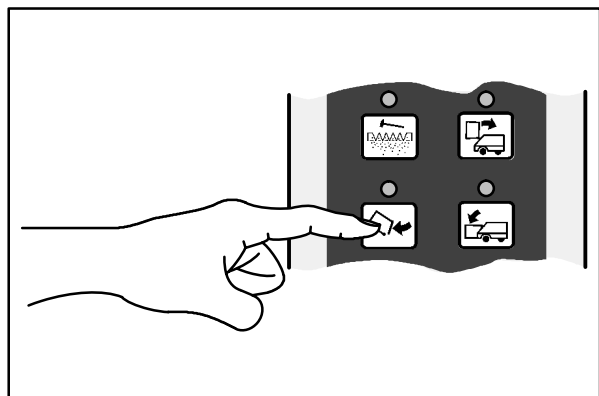

09570

OPERATION

7. Press and hold the hopper down switch  to lower the hopper.

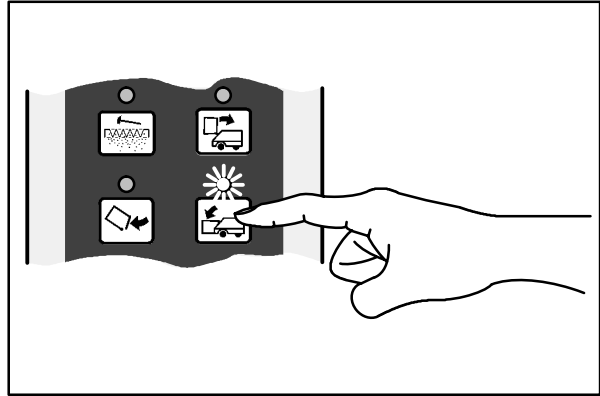

09571

FILLING THE TANKS

1. Start the engine.
2. Drive the machine to the filling site.



3. Stop the solution flow.



4. Shut the engine off.
5. Set the parking brake.



- Open the demister cover. Pour the required amount of detergent into the solution tank. Fill the solution tank to 75 mm (3 in) below the tank opening.

*NOTE: The water must **not be** hotter than 55° C (130° F) or tank damage may occur.*

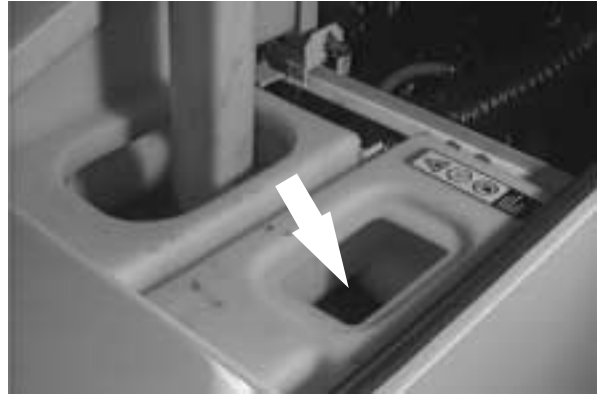

ES™ mode: Lift up the operator seat. Remove the detergent tank lid and pour the required amount of detergent into the tank. Put the lid back on the detergent tank and lower the operator seat.

⚠ WARNING: Flammable materials can cause an explosion or fire. Do not use flammable materials in tank(s).

NOTE: Floor conditions, water condition, amount of soilage, type of soilage, brush action all play an important role in determining the type and concentration of detergent used. For specific recommendations, contact your TENNANT representative.



ES™ mode: Connect a hose from the water source to the auto-fill connections on the machine. Turn the ignition key to the on position and turn on the water source. The auto-fill will automatically fill the tanks to the proper level for ES™ operation and automatically shut-off.

The ES™ tanks can also be filled manually by filling the solution tank to 75 mm (3 in) below tank opening, and filling recovery tank half full.

*NOTE: If you **do not** want to use the ES™ system, do not fill the recovery tank.*

- Close the tanks cover.



SCRUBBING

1. Start the engine.

FOR SAFETY: When starting machine, keep foot on brake and directional pedal in neutral.



2. Select the (Fast) engine speed with the engine speed switch.

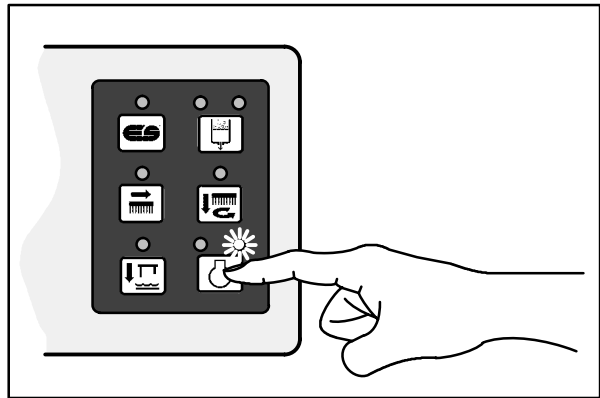

09560

! WARNING: Flammable materials or reactive metals can cause explosion or fire. Do not pick up.

3. Press the scrub brush switch  to lower and start the scrub brushes.

The rear squeegee will automatically lower and the scrubbing vacuum will start, and engine speed will change to (Fast). For the ES™ option, the ES™ system and detergent pump at one-half flow will automatically start.

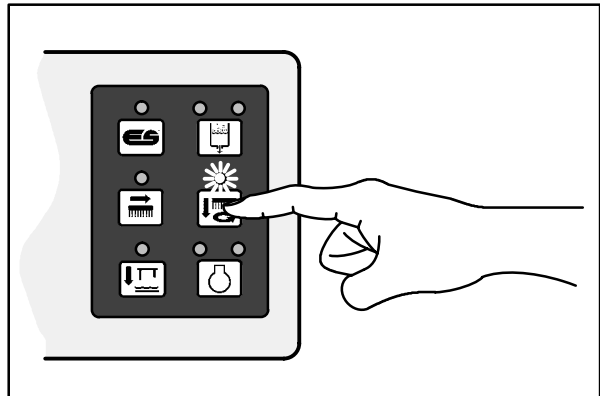

09574

4. Move the solution lever  forward.



*NOTE: If you **do not** want to use the ES™ system, press the ES™ switch so the indicator above the switch is off. Press the detergent switch so that both indicator lights are off.*

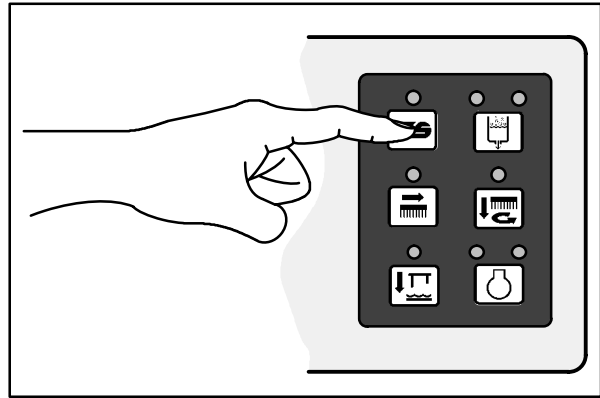

09572

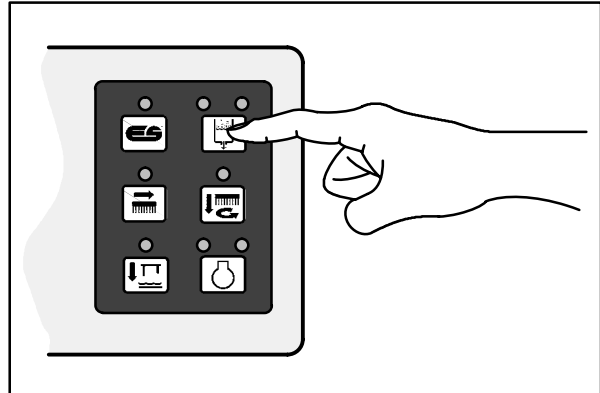

09576

5. Drive the machine forward and scrub as required.
6. Adjust the solution flow to the floor as needed.



7. Adjust brush pressure for cleaning application.



OPERATION

DOUBLE SCRUBBING

Double scrubbing is a method for removing heavy floor accumulations. This is done by making two passes over the area to be cleaned with the machine.

First, make a pass over the area scrubbing with the squeegee up. This dispenses solution over the area allowing the solution to soak on the floor. Let the solution remain on the floor for 5 to 15 minutes. Then make a second pass scrubbing with the squeegee down.

FOR SAFETY: When using machine, go slow on inclines and slippery surfaces.

STOP SCRUBBING

1. Move the solution lever  all the way back.



2. Press the scrub brush switch  to raise and stop the scrub brushes.

The rear squeegee will automatically raise and the scrubbing vacuum will stop. The detergent pump will stop for the ES™ system, but the ES™ pump will remain on. The engine speed will remain at (Fast).

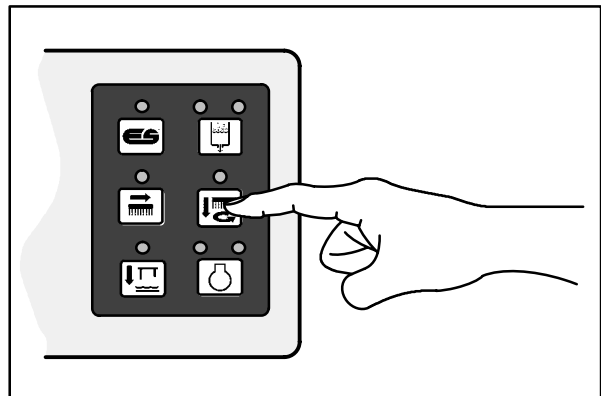

09577

DRAINING AND CLEANING THE TANKS

When you are finished scrubbing or you hear the vacuum fan shut off and the machine starts trailing water, the recovery tank should be drained and cleaned. The solution tank then can be filled again for additional scrubbing.

If you used the machine in ES™ mode, the solution tank should also be drained and cleaned when you are finished scrubbing.

1. Stop scrubbing.
2. Drive the machine next to a floor drain.
3. Shut the engine off.



4. Set the parking brake.



5. Flush out demister cover with clean water.

*NOTE: The water must not be hotter than 55° C (130° F), or tank damage may occur. **Do not** use steam to clean the tank.*



OPERATION

6. Unscrew the drain hose cap from the access cap of the recovery tank drain.
7. Pull out and place the drain hoses next to the floor drain. Remove the drain end cap from the hose. Stand back, the solution rushes out of the drain hoses.



8. Remove the large drain cap and flush out the bottom on the recovery tank.
9. Open the demister cover.
10. Spray the inside of the recovery tank with clean water.

NOTE: The water must not be hotter than 55° C (130° F), or tank damage may occur. Do not use steam to clean the tank.

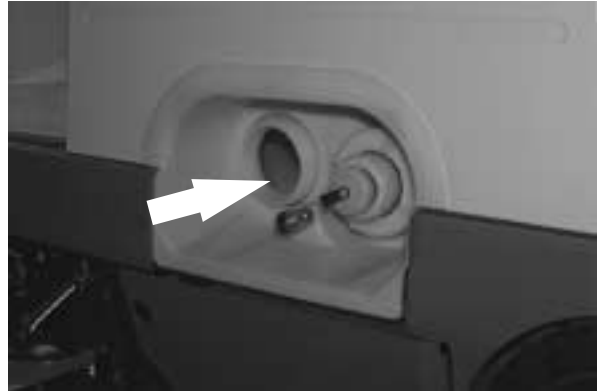

11. ES™ mode: Open the recovery tank cover. Disconnect the ES™ pump wire. Remove the solution hose from the solution tank.

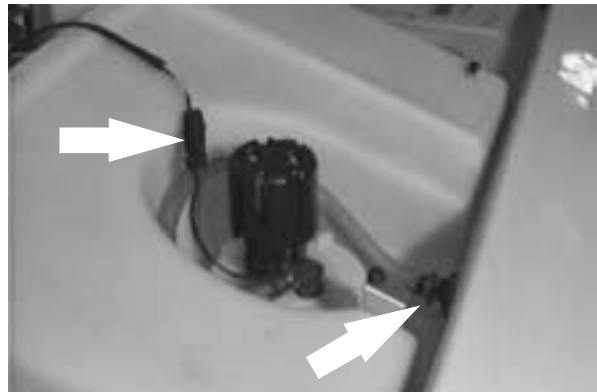

Unscrew the cap and ES™ pump from the top of the recovery tank. Clean the ES™ filter. Place the filter back in the recovery tank and connect the ES™ pump wire and solution hose.

12. ES™ mode: Drain the solution tank. Flush out the solution tank with clean water.

NOTE: The water must not be hotter than 55° C (130° F), or tank damage may occur. Do not use steam to clean the tank.

13. Lower the recovery tank cover and demister cover.
14. Replace the drain hoses and drain caps.



STOP THE MACHINE

1. Stop sweeping and scrubbing.
2. Take your foot off the directional pedal. Step on the brake pedal.

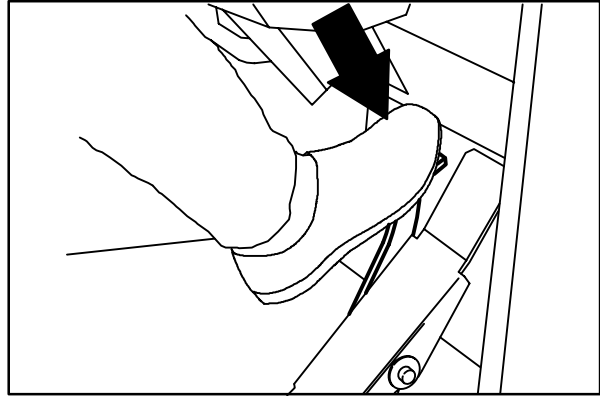

07754

3. Select the (Idle) position with the engine speed switch .

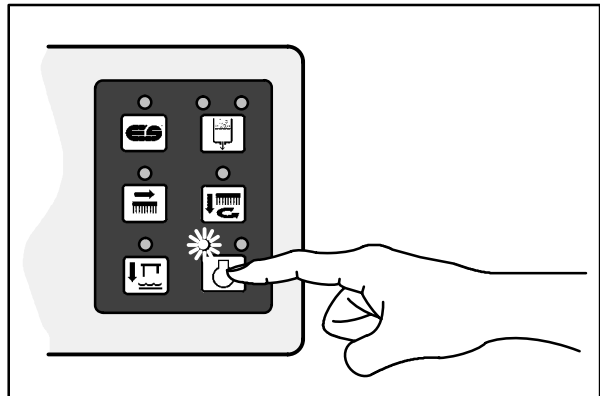

09578

4. Set the machine parking brake.



OPERATION

5. Turn the ignition switch key counter-clockwise to stop the engine. Remove the switch key.

FOR SAFETY: Before leaving or servicing machine; stop on level surface, set parking brake, turn off machine and remove key.



6. LPG powered machines: Close the LPG tank's liquid service valve.

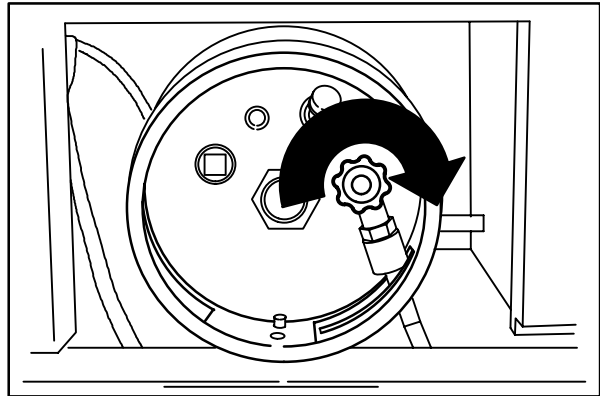

07810

POST-OPERATION CHECKLIST

- Check the brushes adjustment. See *TO CHECK AND ADJUST MAIN BRUSH PATTERN* and *SIDE BRUSH* in *MAINTENANCE*.
- Check the brush skirts for damage, wear, and adjustment.

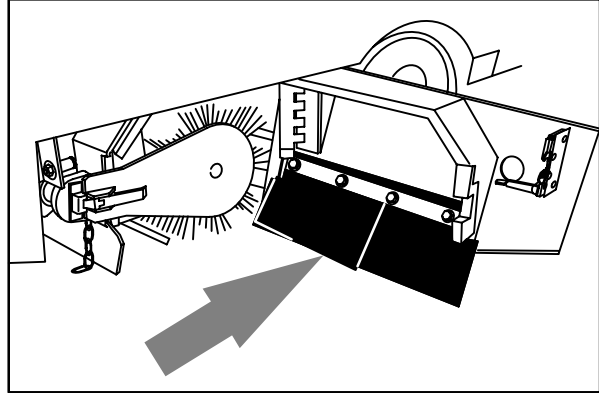

08001

- Check for wire or string tangled on the main, scrub, and side brushes

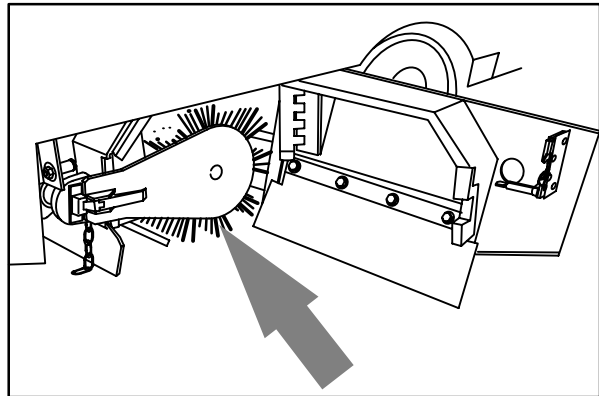

08002

- Check the squeegees for wear or damage.
- Drain and clean the recovery tank.
- ES™ mode: Drain and clean the solution tank. Clean the ES™ filter.
- Check the vacuum hoses for debris or obstructions.



OPERATION

- LPG powered machine: Check to make sure the LPG tank service valve is closed.

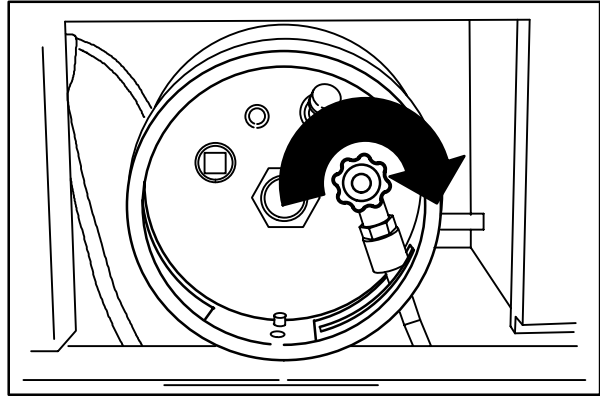

07810

- Check for fuel odor that indicates a fuel leak.
- Check under the machine for leak spots (fuel, oil, coolant).
- Check the service records to determine maintenance requirements.

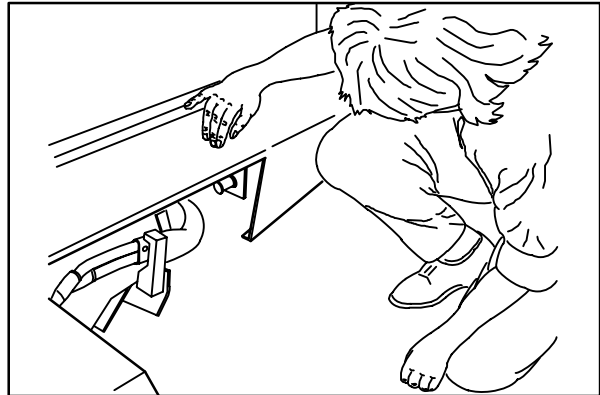

07807

ENGAGING HOPPER SUPPORT BAR

1. Set the machine parking brake.

FOR SAFETY: When starting machine, keep foot on brake and directional pedal in neutral.



2. Start the engine.



3. Raise the hopper all the way up.

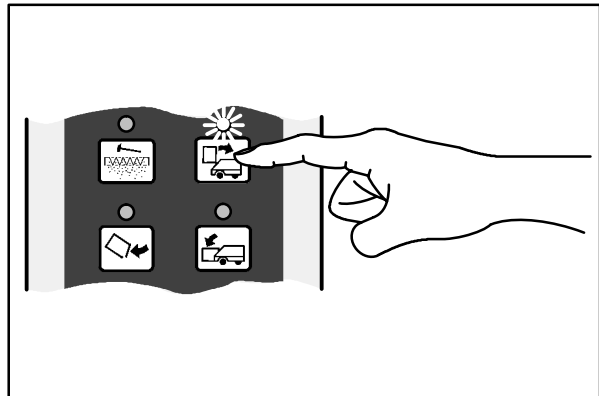

09569

4. Lift and position the hopper support bar under the hopper lift arm.

⚠ WARNING: Raised hopper may fall. Engage hopper support bar.

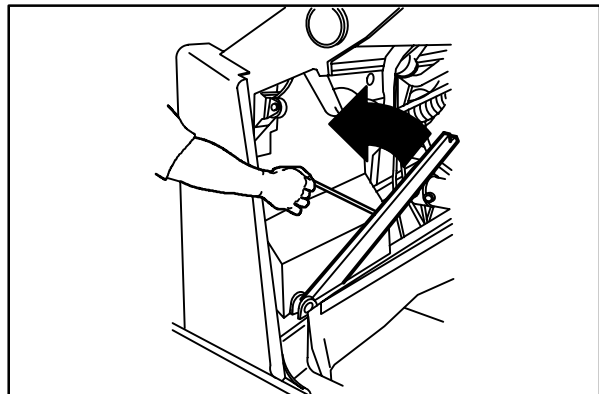

08003

OPERATION

5. Slowly lower the hopper so the lift arm rests on the support bar.



WARNING: Lift arm pinch point. Stay clear of hopper lift arms.

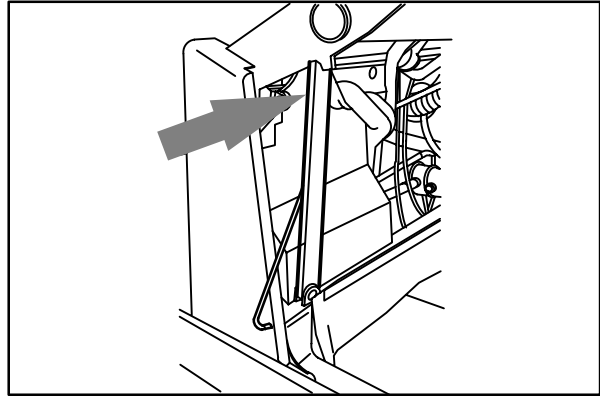

07803

6. Shut the engine off.



DISENGAGING HOPPER SUPPORT BAR

1. Start the engine.

FOR SAFETY: When starting machine, keep foot on brake and directional pedal in neutral.



2. Raise the hopper slightly to release the hopper support bar.

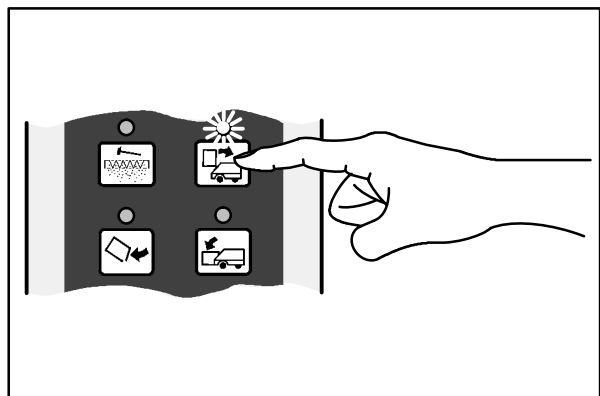

09569

- Put the support bar in its storage position.



WARNING: Lift arm pinch point. Stay clear of hopper lift arms.

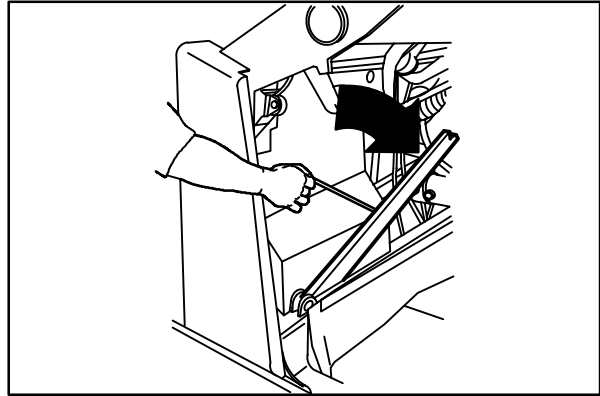

08004

- Lower the hopper.

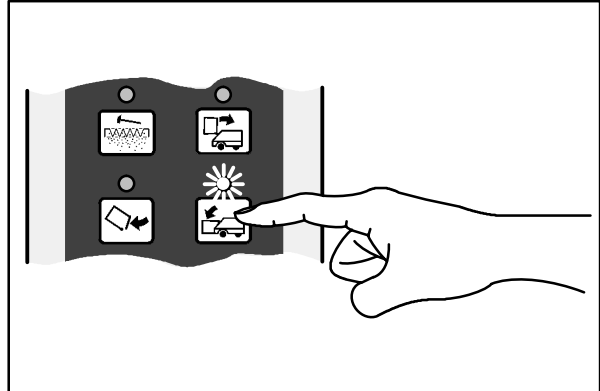

09571

- Shut the engine off.



OPERATION ON INCLINES

Drive the machine slowly on inclines. Use the brake pedal to control machine speed on descending inclines.

The maximum rated incline is 8°.

FOR SAFETY: When using machine, go slow on inclines and slippery surfaces.

OPTIONS

VACUUM WAND (WET)

The vacuum wand uses the machine's vacuum system. The vacuum hose allows pick-up of spills that are out of reach of the machine.

1. Stop the machine within reach of the area to be vacuumed.
2. Lower the squeegee and shut the engine off.

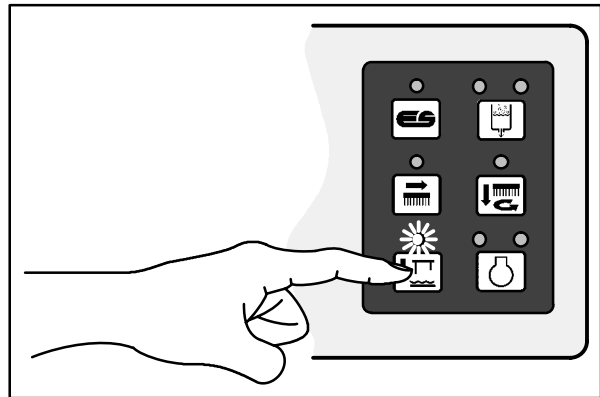

09575



3. Set the machine parking brake.

FOR SAFETY: Before leaving or servicing machine; stop on level surface, set parking brake, turn off machine and remove key.



4. Remove the squeegee suction hose from the rear squeegee and connect the vacuum hose.



5. Put together the wand and the wand hose.
6. Start the engine.



7. Select the (Fast) engine speed with the engine speed switch .

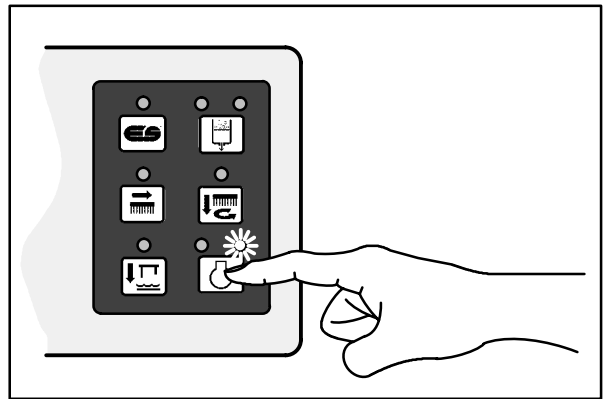

09560

8. Lower the squeegee to turn the vacuum system on.

OPERATION

9. Vacuum the floor.



10. Shut the engine off.



11. Remove the vacuum hose from the squeegee suction hose and connect the squeegee suction hose to the rear squeegee.

12. Put the vacuum wand and hose in the mounting clips.



TIE-DOWNS

The machine can be tied down for transport using the tie-down brackets at the front and rear of the machine.

The front tie-down bracket is above the front tires.

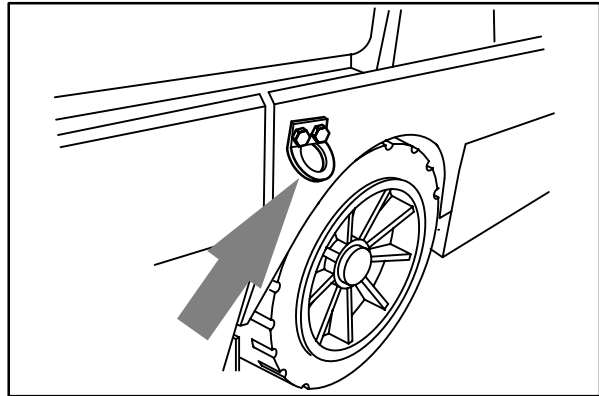

08152

The rear tie-down is located on both sides of the tail light bracket under the rear bumper.

When transporting the machine on a trailer or in a truck, be sure to set the parking brake and block the tires to prevent the machine from rolling.

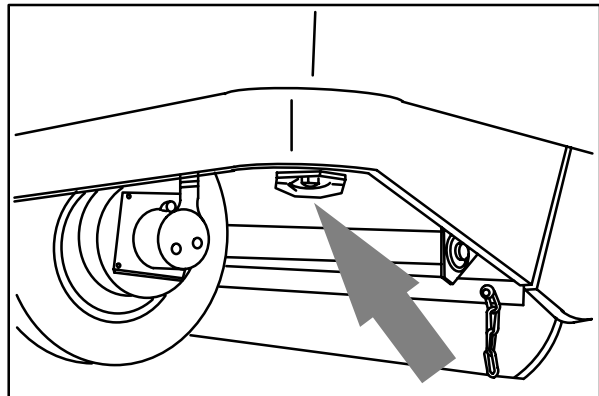

08151

OPERATION

MACHINE TROUBLESHOOTING

Problem	Cause	Remedy
Excessive dusting	Brush skirts and dust seals worn, damaged, out of adjustment	Replace or adjust brush skirts or dust seals
	Hopper dust filter clogged	Shake and/or clean or replace dust filter
	Vacuum hose damaged	Replace vacuum hose
	Vacuum fan failure	Contact TENNANT service personnel
	Thermo Sentry™ tripped	Reset Thermo Sentry™
Poor sweeping performance	Brush bristles worn	Replace brushes
	Main and side brushes not adjusted properly	Adjust main and side brushes
	Debris caught in main brush drive mechanism	Free drive mechanism of debris
	Main brush drive failure	Contact TENNANT service personnel
	Side brush drive failure	Contact TENNANT service personnel
	Hopper full	Empty hopper
	Hopper lip skirts worn or damaged	Replace lip skirts
	Wrong sweeping brush	Contact TENNANT representative for recommendations

Problem	Cause	Remedy	
Trailing water – poor or no water pickup.	Worn rear squeegee blades.	Rotate or replace squeegee blades.	
	Rear squeegee out of adjustment.	Adjust rear squeegee.	
	Side squeegees raised.	Lower side squeegees.	
	Worn side squeegee blades.	Replace side squeegee blades.	
	Side squeegees out of adjustment.	Adjust side squeegees.	
	Demister cover not seated.	Reseat demister cover.	
	Demister cover seals worn.	Replace seals.	
	Too much solution flow to floor.	Reduce solution flow to floor.	
	Vacuum hose clogged.	Flush vacuum hoses.	
	Recovery tank full.		Drain recovery tank.
			Check ES™ pump and filter
	Float stuck shutting off vacuum.	Clean float.	
	Debris caught on rear squeegee.	Remove debris.	
	Foam filling recovery tank.	Empty recovery tank; use less or change detergent.	
	Vacuum hose to rear squeegee disconnected or damaged.	Reconnect or replace vacuum hose.	
Vacuum fan to recovery tank hose damaged.	Replace hose.		
Little or no solution flow to the floor.	Solution tank empty.	Fill solution tank.	
	Solution control linkage out of adjustment.	Replace and/or adjust cable.	
	Solution supply lines plugged.	Flush solution supply lines.	
	ES™ switch off.	Turn ES™ switch on.	
Poor scrubbing performance.	Debris caught on scrub brushes.	Remove debris.	
	Improper detergent or brushes used.	Check with TENNANT representative for advice.	
	Worn scrub brushes.	Replace scrub brushes.	
ES™ system does not fill solution tank.	Clogged solution pump or lines.	Flush ES™ system.	
	ES™ float stuck.	Clean floats of debris.	
	Clogged ES™ pump filter.	Clean filter.	
	Water levels too low in tanks.	Add water.	

MAINTENANCE

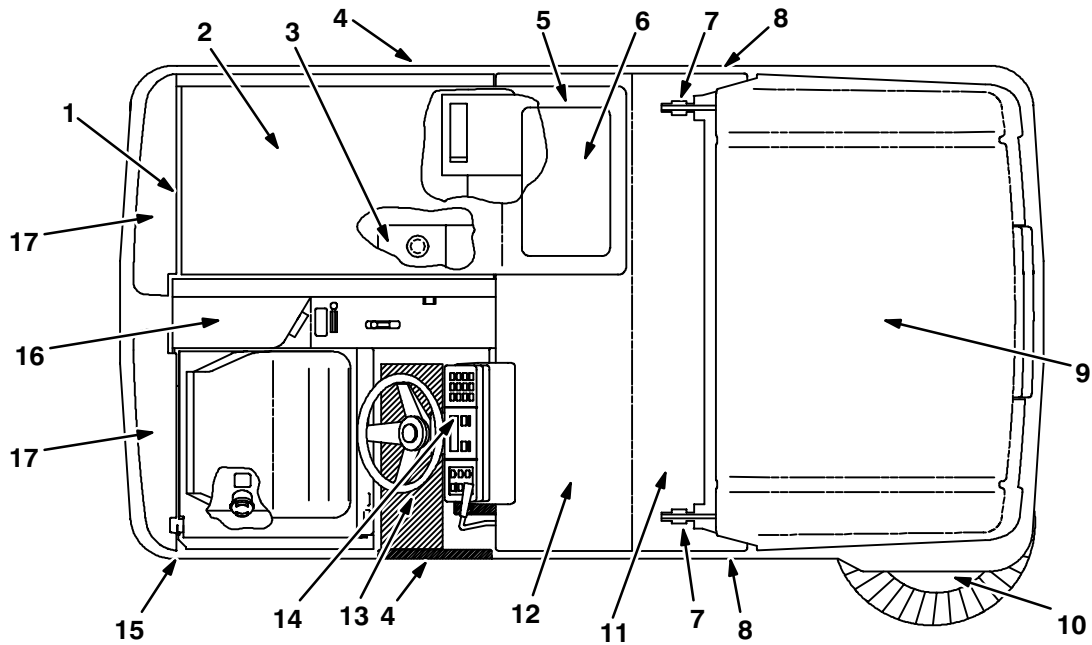

09076

MAINTENANCE CHART

Interval	Key	Description	Procedure	Lubricant/ Fluid	No. of Service Points
Daily	2	Engine air filter	Check indicator	—	1
			Empty dust cap	—	1
	2	Engine crankcase	Check oil level	EO	1
	11	Brush compartment skirts	Check for damage, wear and adjustment	—	5
	9	Hopper lip skirts	Check for damage, wear and adjustment	—	3
	11	Main brush	Check for damage, wear, and adjustment	—	1
			Check brush pattern	—	1
	10	Side brush	Check for damage, wear, and adjustment	—	1
			Check brush pattern	—	1
	9	Hopper dust filter	Shake	—	2
	15	Rear Squeegee	Check for damage and wear	—	1
			Check deflection	—	1
	4	Side Squeegees	Check for damage and wear	—	2
	4	Scrub brushes	Check for damage and wear	—	1
5	Recovery tank	Clean	—	1	
12	Recovery tank, ES™ mode	Clean ES™ filter	—	1	
6	Solution tank, ES™ mode	Clean	—	1	
50 Hours	11	Main brush	Rotate end-for-end	—	1
	17	Rear squeegee casters	Lubricate	SPL	2
100 Hours	1	Radiator	Clean core exterior	—	1
			Check coolant level	WG	1
	2	Engine crankcase	Change oil and filter element	EO	1

MAINTENANCE

Interval	Key	Description	Procedure	Lubricant/ Fluid	No. of Service Points	
100 Hours	2	Engine	Check belt tension	–	1	
			Check and adjust idle speed	–	1	
			Check and adjust idle mixture	–	1	
	9	Hopper dust filter	Check for damage, clean or replace	–	1	
			3	Hydraulic fluid reservoir	Check fluid level	HYDO
	11	Main brush and hopper seals	8	Tires	Check for damage	–
11			Main brush and hopper seals	Check for damage or wear	–	8
15			Rear squeegee	Check leveling	–	1
200 Hours	1	Radiator hoses and clamps	Check for tightness and wear	–	2	
			14	Parking brake	Check adjustment	–
	14	Brake pedal	Check and adjust travel	–	1	
	16	Rear wheel support bearings	Lubricate	SPL	1	
	10	Side brush guard	Rotate 90°	–	1	
	7	Lift arm pivots	Lubricate	SPL	4	
	9	Hopper door pivots	Lubricate	SPL	2	
400 Hours	8	Front wheel bearings	Check, lubricate, and adjust	SPL	2	
			1	Cooling system	Flush	WG
	2	Engine	Clean or replace and adjust spark plugs	–	4	
			Replace PCV valve	–	1	
			Check distributor	–	1	
			Fuel filter, gasoline	–	2	
800 Hours	3	Hydraulic reservoir	Replace filler cap	–	1	
			Replace suction strainer	–	1	
			Change hydraulic fluid	HYDO	1	
	3	Hydraulic fluid filter	Change filter element	–	1	
			–	Hydraulic hoses	Check for wear and damage	–
	16	Propelling motor	■ Torque shaft nut	–	1	
	16	Rear wheel	■ Torque wheel nuts	–	1	
	13	Battery	■ Clean and tighten battery cable connections	–	1	
			Check electrolyte	DW	1	
			2	Engine	Clean PCV hoses, tubes, and fittings	–
Torque intake manifold bolts			–	8		
Check timing belt	–	1				
1600 Hours	2	Engine	Replace timing belt	–	1	

LUBRICANT/FLUID

EO . . . Engine oil, SAE–CC/CD rated

HYDO . . . Tennant or approved hydraulic fluid

WG . . . Water and permanent-type ethylene glycol anti-freeze, –34° C (–30° F)

SPL . . . Special lubricant, Lubriplate EMB grease (TENNANT part no. 01433–1)

DW . . . Distilled water

NOTE: Also check procedures indicated (■) after the first 50-hours of operation.

NOTE: More frequent intervals may be required in extremely dusty conditions.

LUBRICATION

ENGINE

Check the engine oil level daily. Change the engine oil and oil filter every 100 hours of machine operation. Use 10W30 SAE–SG/SH rated engine oil.

Fill the engine with oil to the level indicated on the oil dipstick. The engine oil capacity is 4.7 L (5 qt) including the oil filter.



REAR WHEEL SUPPORT

The rear wheel support pivots the rear wheel. The support has one grease fitting for the bearings. The rear wheel support bearings must be lubricated every 200 hours of operation. Use Lubriplate EMB grease (TENNANT part no. 01433–1).

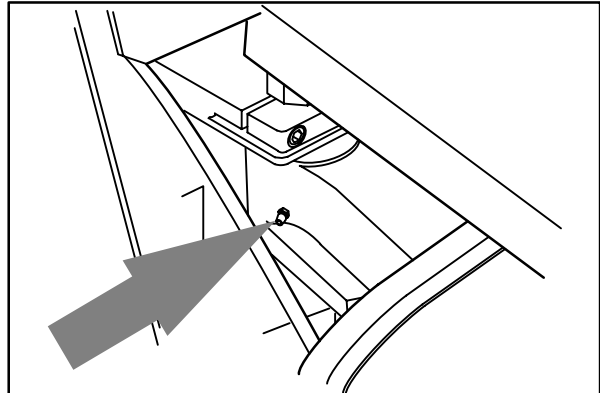

08005

FRONT WHEEL BEARINGS

Inspect the front wheel bearings for seal damage, and repack and adjust every 400 hours of operation. Use Lubriplate EMB grease (TENNANT part no. 01433–1).

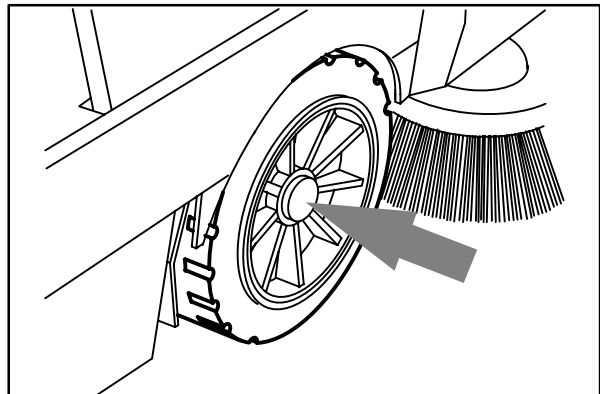

08006

HOPPER LIFT ARM PIVOTS

The hopper lift arms have four grease fittings, two on each lift arm. One fitting is at the top pivot of the lift arm, and the other is at the middle pivot.

The lift arms should be lubricated with Lubriplate EMB grease (TENNANT part no. 01433-1) every 200 hours of operation.



HOPPER DOOR PIVOTS

The hopper door pivot has two grease fittings, one on each side of the hopper. The hopper door should be lubricated with Lubriplate EMB grease (TENNANT part no. 01433-1) every 200 hours of operation.

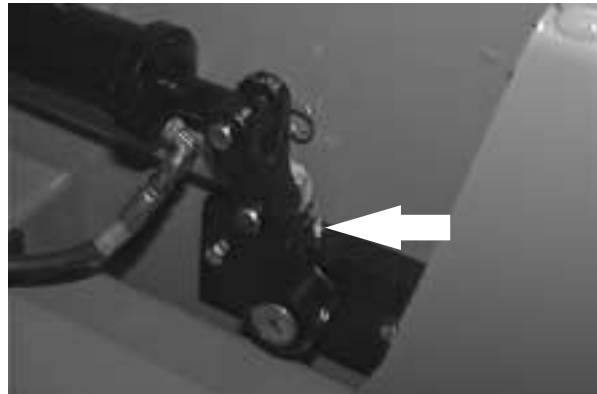

REAR SQUEEGEE CASTERS

Each of the rear casters has a grease fitting. The casters must be lubricated every 50 hours of operation. Use Lubriplate EMB grease (Tennant part no. 01433-1).



HYDRAULICS

HYDRAULIC FLUID RESERVOIR

The reservoir is located in the engine compartment next to the radiator.

Mounted on top of the reservoir is a filler cap with a built-in breather and fluid level dipstick. Replace the cap every 800 hours of operation.

Check the hydraulic fluid level at operating temperature every 100 hours of operation. Make sure the hopper is down when checking hydraulic fluid level. The end of the dipstick is marked with FULL and ADD levels to indicate the level of hydraulic fluid in the reservoir.

Lubricate the filler cap gasket with a film of hydraulic fluid before putting the cap back on the reservoir.

ATTENTION! Do not overfill the hydraulic fluid reservoir or operate the machine with a low level of hydraulic fluid in the reservoir. Damage to the machine hydraulic system may result.

Drain and refill the hydraulic fluid reservoir with new hydraulic fluid every 800 hours of operation.

The hydraulic fluid filter is located at the bottom of the engine compartment. Replace the filter element every 800 hours of operation.

The reservoir has a built-in strainer outlet that filters hydraulic fluid before it enters the system. Replace the strainer every 800 hours of operation.

HYDRAULIC FLUID

The quality and condition of the hydraulic fluid play a very important role in how well the machine operates. Tennant's hydraulic fluid is specially selected to meet the needs of Tennant machines.

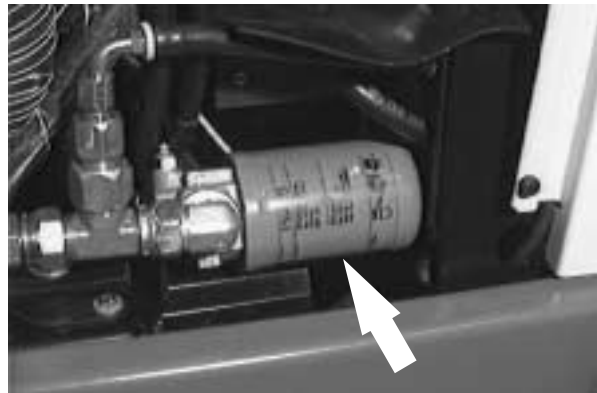

Tennant's hydraulic fluids provide a longer life for the hydraulic components. There are two fluids available for different temperature ranges:

Tennant part no.	Ambient Temperature
65869	above 7° C (45° F)
65870	below 7° C (45° F)

The higher temperature fluid has a higher viscosity and should not be used at the lower temperatures. Damage to the hydraulic pumps may occur because of improper lubrication.

The lower temperature fluid is a thinner fluid for colder temperatures.

If a locally-available hydraulic fluid is used, make sure the specifications match Tennant hydraulic fluid specifications. Using substitute fluids can cause premature failure of hydraulic components.

European manufactured machines are filled with locally available hydraulic fluids. Check the label on the hydraulic fluid reservoir.

ATTENTION! Hydraulic components depend on system hydraulic fluid for internal lubrication. Malfunctions, accelerated wear, and damage will result if dirt or other contaminants enter the hydraulic system.

HYDRAULIC HOSES

Check the hydraulic hoses every 800 hours of operation for wear or damage.

Fluid escaping at high pressure from a very small hole can be almost invisible, and can cause serious injuries.

See a doctor at once if injury results from escaping hydraulic fluid. Serious infection or reaction can develop if proper medical treatment is not given immediately.

FOR SAFETY: When servicing machine, use cardboard to locate leaking hydraulic fluid under pressure.

If you discover a fluid leak, contact your mechanic/supervisor.

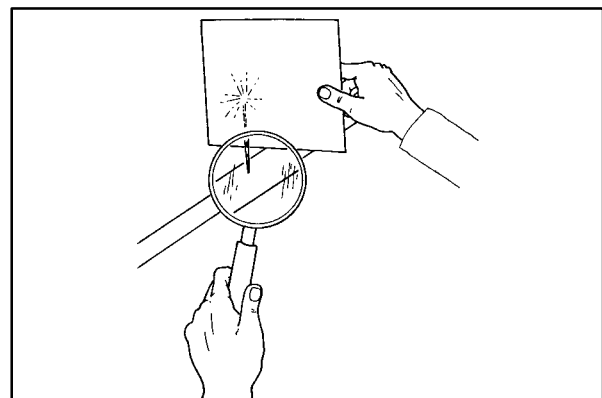

00002

PROPELLING MOTOR

Torque the shaft nut to 508 Nm (375 ft lb) lubricated, 644 Nm (475 ft lb) dry after the first 50-hours of operation, and every 800 hours thereafter.

ENGINE

COOLING SYSTEM

Check the radiator coolant level every 100 hours of operation. Use clean water mixed with a permanent-type, ethylene glycol antifreeze to a -34°C (-30°F) rating.

FOR SAFETY: When servicing machine, avoid contact with hot engine coolant.

Check the radiator hoses and clamps every 200 hours of operation. Tighten the clamps if they are loose. Replace the hoses and clamps if the hoses are cracked, harden, or swollen.

Check the radiator core exterior and hydraulic cooler fins for debris every 100 hours of operation. Blow or rinse all dust, which may have collected on the radiator, in through the grille and radiator fins, opposite the direction of normal air flow. Be careful not to bend the cooling fins when cleaning. Clean thoroughly to prevent the fins becoming encrusted with dust. Clean the radiator and cooler only after the radiator has cooled to avoid cracking.

FOR SAFETY: When servicing machine, wear eye and ear protection when using pressurized air or water.

Flush the radiator and the cooling system every 800 hours of operation, using a dependable cleaning compound.

AIR FILTER INDICATOR

The air filter indicator shows when to clean or replace the air filter element. Check the indicator daily. The indicator's red line will move as the air filter element fills with dirt. Do not clean or replace the air filter element until the red line reaches 5 kPa (20 in H₂O) and the "SERVICE WHEN RED" window is filled with red. The indicator's red line may return to a lower reading on the scale when the engine shuts off. The red line will return to a correct reading after the engine runs for a while.

Reset the air filter indicator by pushing the reset button on the end of the indicator after cleaning or replacing the air filter element.



AIR FILTER

The engine air filter housing has a dust cap and a dry cartridge-type air filter element. Empty the dust cap daily. The air filter must be replaced whenever the filter element is damaged or has been cleaned three times.

Machine with the heavy duty air filter option have a safety element. It is inside the standard element. Replace this element, do not clean it, after the regular element has been damaged or cleaned three times.



Install the dust cap on the air filter housing with the arrows pointing up.

Service the air filter element only when the air filter indicator shows restriction in the air intake system. Do not remove the air filter element from the housing unless it is restricting air flow.

To clean the filter element, remove it from the filter housing. Carefully clean the end cap and the interior of the housing with a damp cloth. Clean the housing sealing surfaces.

Using an air hose, direct clean, dry air, maximum 205 kPa (30 psi), up and down the pleats on the inside of the element. Do not rap, tap or pound dust out of the element.

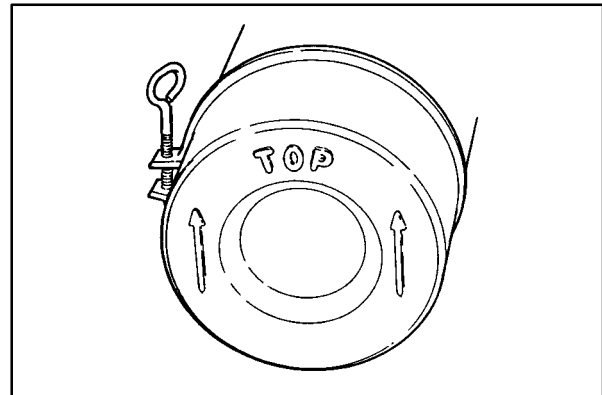

02492

FOR SAFETY: When servicing machine, wear eye and ear protection when using pressurized air or water.

After cleaning the air filter element, inspect it for damage by placing a bright light inside. The slightest rupture requires replacement of the element. Inspect the seals on the ends of the element, they should be flexible and undamaged.

FUEL FILTER

The fuel filter traps fuel contaminants. The filter is located on the fuel line going into the carburetor.

Replace the filter elements every 400 hours of operation.

CARBURETOR

The carburetor has two basic adjustments. Those adjustments are idle fuel mixture and idle speed. Check and adjust idle fuel mixture and idle speed every 100 hours of operation.

FOR SAFETY: When servicing machine, allow engine to cool. Keep flames and sparks away from fuel system service area. Keep area well ventilated.

Idle speed is 1450 rpm with no power to the electronic governor.

SPARK PLUGS

Clean or replace, and set the gap of the spark plugs every 400 hours of operation.

The proper spark plug gap is 1 mm (0.042 in).

DISTRIBUTOR

Check and clean the distributor every 400 hours of operation. The distributor is breakerless.

Dusty conditions and high engine operating speeds may require more frequent inspections of the distributor.

CRANKCASE VENTILATION SYSTEM

Replace the PCV valve every 400 hours of operation. Clean the crankcase ventilation hoses, tubes, and fittings every 800 hours of operation.

INTAKE MANIFOLD

Tighten the intake manifold bolts or nuts every 800 hours of operation. They are tighten in a two step sequence. Torque the M8 bolts or nuts to 7 to 9.5 Nm (5 to 7 ft lb) in the first step, and 19 to 28.5 Nm (14 to 21 ft lb) in the second step of torquing.

TIMING BELT

Check the engine timing belt every 800 hours of operation, and replace the engine timing belt every 1600 hours of operation.

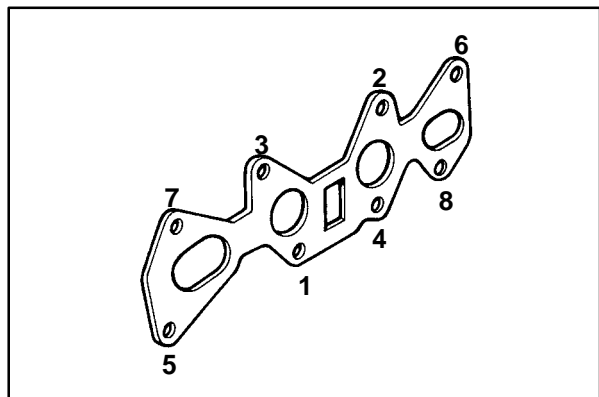

06805

BATTERY

The battery for the machine is a low maintenance battery. Do not add water to the battery, or remove the battery vent plugs.

The battery is located at the bottom of the operator compartment.

After the first 50 hours of operation, and every 800 hours after that, clean and tighten the battery connections.

FOR SAFETY: When servicing machine, avoid contact with battery acid.



BELTS AND CHAINS

ENGINE BELT

The engine belt is driven by the engine crankshaft pulley and drives the water pump and alternator pulleys. Proper belt tension is 13 mm (0.50 in) from a force of 4 to 5 kg (8 to 10 lb) applied at the mid-point of the longest span.

Check and adjust the belt tension every 100 hours of operation.

 **WARNING: Moving belt and fan. Keep away.**

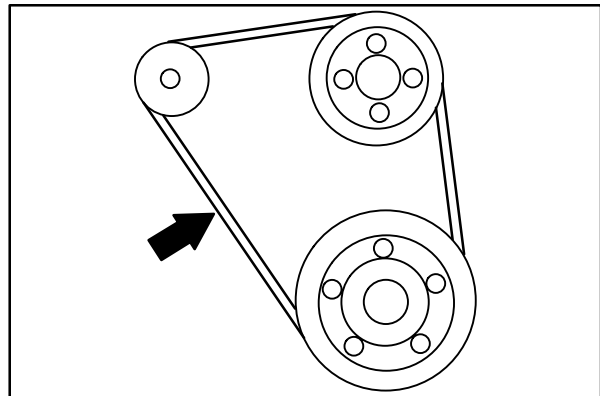

08935

STATIC DRAG CHAIN

A static drag chain prevents the buildup of static electricity in the machine. The chain is attached to the machine by a rear main brush skirt retaining bolt.

Make sure the chain is touching the floor at all times.

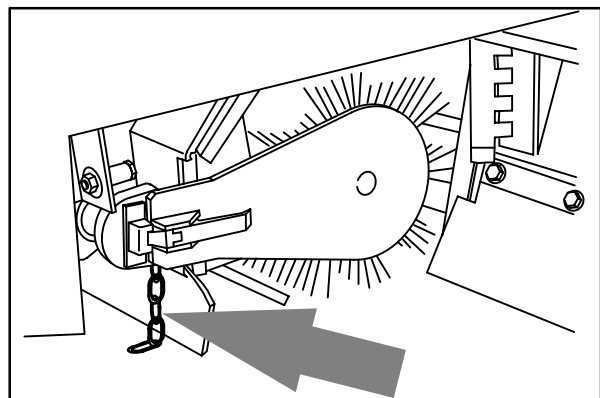

08009

DEBRIS HOPPER

HOPPER DUST FILTER

The dust filter filters the air pulled up from the hopper. The dust filter is equipped with a shaker to remove the accumulated dust particles. The dust filter shaker is operated by the filter shaker switch.

Shake the dust filter before emptying the hopper and at the end of every work shift. Check and clean or replace the dust filter every 100 hours of operation.

To clean the dust filter, use one of the following methods:

- **SHAKING** – Press the filter shaker switch.
- **TAPPING** – Tap the filter gently on a flat surface with the dirty side down. Do not damage the edges of the filter element or the filter will not seat properly in the filter frame.
- **AIR** – Blow air through the dust filter opposite the direction of the arrows. This may be done with the dust filter in the machine. Always wear eye protection when using compressed air.

FOR SAFETY: When servicing machine, wear eye and ear protection when using pressurized air or water.

- **WATER** – Soak the dust filter in a water and mild detergent solution. Rinse the dust filter until it is clean. Air dry the wet dust filter; do not use compressed air.

NOTE: Be sure the dust filter is dry before reinstalling it in the machine.

REMOVING HOPPER DUST FILTER

1. Stop the engine and set the machine parking brake.

FOR SAFETY: Before leaving or servicing machine; stop on level surface, set parking brake, turn off machine and remove key.

2. Open the hopper cover.

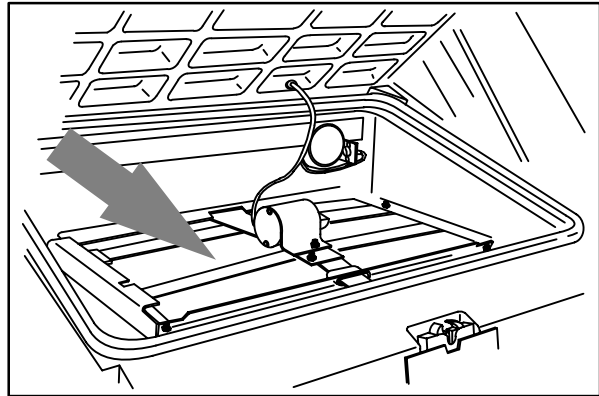

08010

3. Disconnect the shaker motor wire connectors.

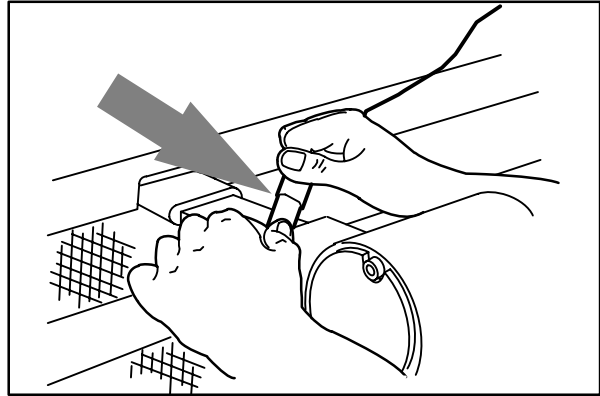

08011

4. Remove the four retaining nuts from the filter shaker frame.
5. Pull the filter shaker frame out of the hopper.

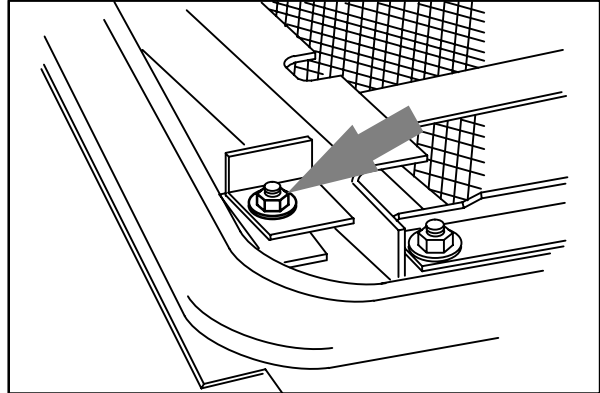

08014

6. Lift the dust filter element out of the hopper insert.
7. Clean or discard the dust filter as required.

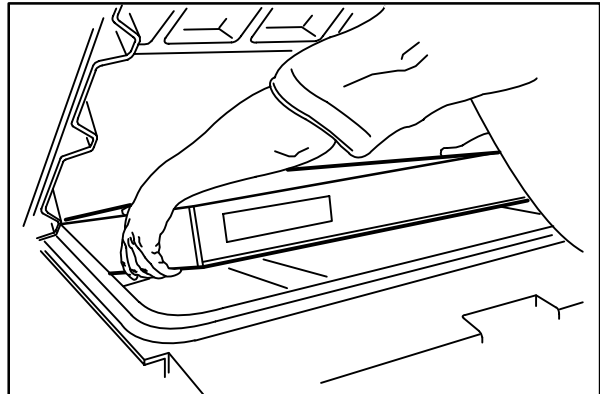

08012

8. Put the cleaned or new dust filter in the hopper insert with the arrows pointing up.
9. Put the shaker frame on top of the panel filter.
10. Install the four retaining nuts and tighten.
11. Connect the shaker motor wire connectors.

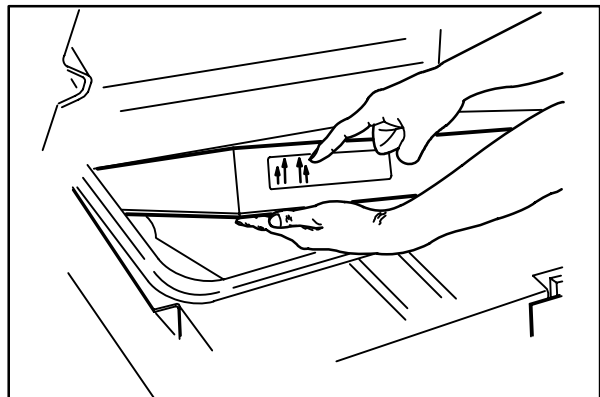

08013

MAINTENANCE

THERMO SENTRY™

The Thermo Sentry™ senses the temperature of the air pulled up from the hopper. If there is a fire in the hopper, the Thermo Sentry™ stops the vacuum fan and cuts off the air flow.

Reset the Thermo Sentry™ by pushing in its reset button.

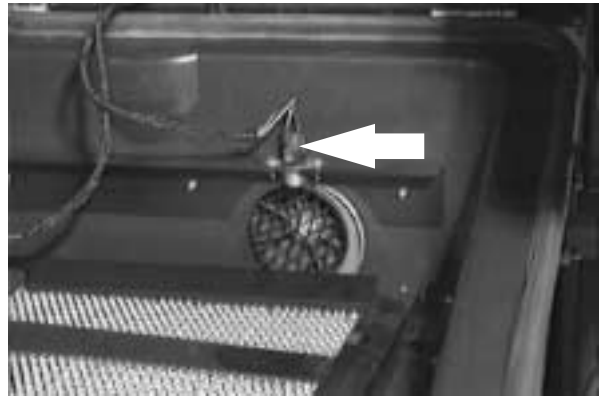

SCRUB HEAD

The scrub head encloses the scrub brushes and a solution dispensing system. The scrub head is located directly behind the sweeping brush compartment.

The scrub head is factory adjusted and the measurement should not be changed unless scrub head parts are damaged or are replaced.

BRUSHES

MAIN BRUSH

The main brush is cylindrical and spans the width of the machine, sweeping debris into the hopper.

Check the brush daily for wear or damage. Remove any string or wire tangled on the main brush, main brush drive hub, or main brush idler hub.

Check the main brush pattern daily. The pattern should be 50 to 65 mm (2.0 to 2.5 in) wide with the main brush in the lowered position. Adjust the main brush pattern by turning the main brush pressure knob located next to the brush position lever.

Rotate the main brush end-for-end every 50 hours of operation for maximum brush life and best sweeping performance.

Replace the main brush when the remaining bristles measure 25 mm (1 in) in length.

REPLACING MAIN BRUSH

1. Stop the engine and set the machine parking brake.

FOR SAFETY: Before leaving or servicing machine; stop on level surface, set parking brake, turn off machine and remove key.

2. Raise the main brush.
3. Open the right side main brush access door.
4. Unlatch and remove the brush idler plate.

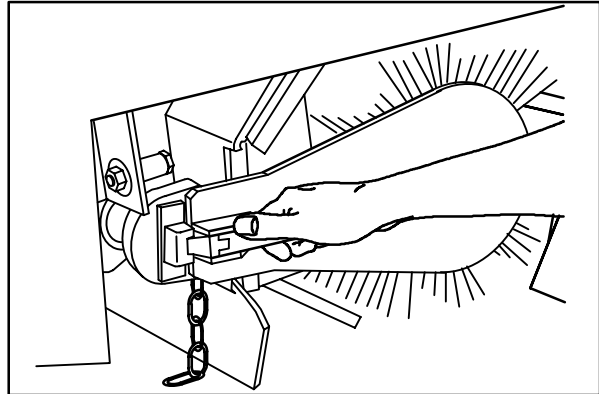

08016

5. Grasp the main brush; pull it off the brush drive plug and out of the main brush compartment.
6. Put the new or rotated end-for-end main brush on the floor next to the access door.
7. Slide the main brush onto the drive plug. Rotate the brush until it engages the drive plug, and push it all the way onto the plug.
8. Slide the main brush idler plate plug onto the main brush.
9. Latch the idler plate onto the machine frame.
10. Close the right side main brush access door.

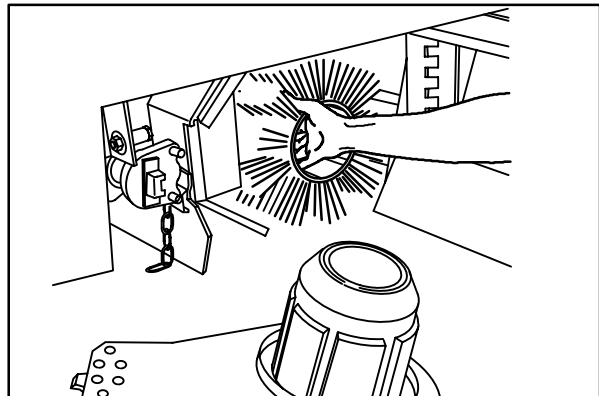

08017

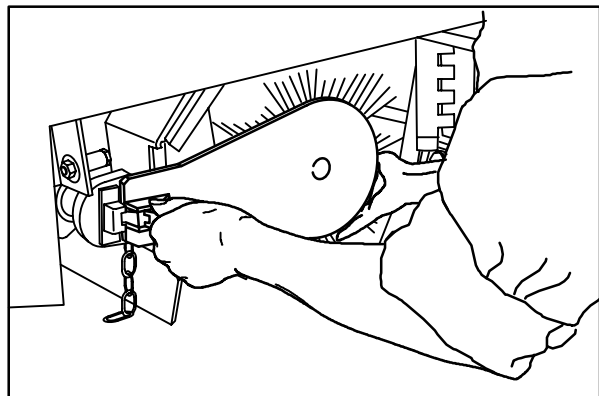

08018

CHECKING AND ADJUSTING MAIN BRUSH PATTERN

1. Apply chalk, or some other material that will not blow away easily, to a smooth, level floor.
2. Raise the side brush and main brush and position the main brush over the chalked area.
3. Start the main brush.
4. Lower the main brush for 15 to 20 seconds while keeping a foot on the brakes to keep the machine from moving. This will lower the rotating main brush.

NOTE: If chalk or other material is not available, allow the brushes to spin on the floor for two minutes. A polish mark will remain on the floor.

5. Raise the main brush.
6. Stop the main brush.
7. Drive the machine off the test area.
8. Observe the width of the brush pattern. The proper brush pattern width is 50 to 65 mm (2.0 to 2.5 in).

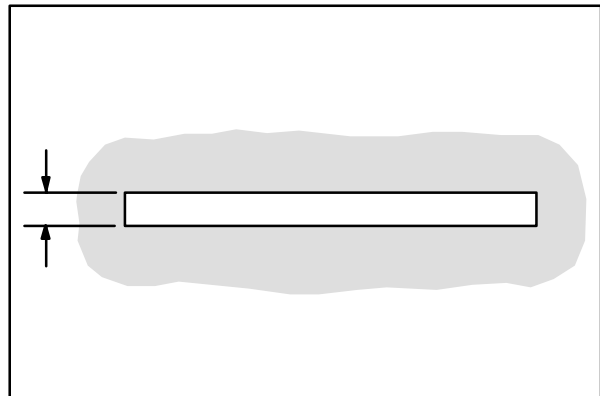

00582

9. To increase the width of the main brush pattern, turn the main brush down pressure knob counter-clockwise.

To decrease the width of the main brush pattern, turn the main brush down pressure knob clockwise.



If the main brush pattern is tapered, more than 15 mm (0.5 in) on one end than the other, adjust the taper with the taper adjustment bracket at the idler end of the brush.

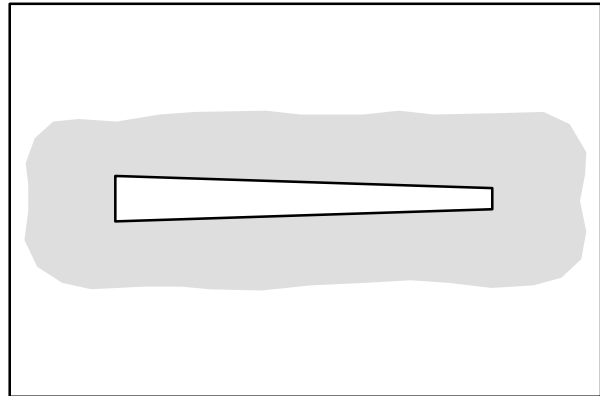

00601

- A. Loosen the bracket mounting bolts.

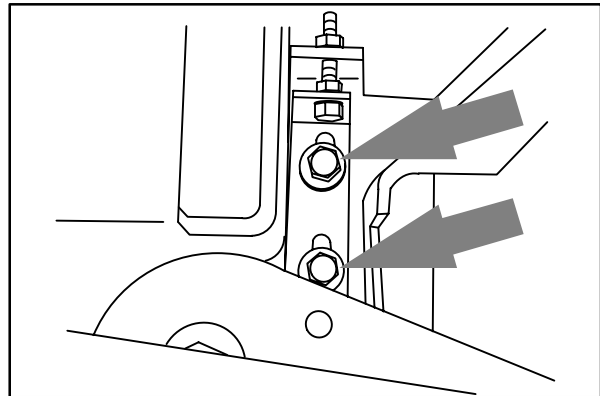

09183

- B. Turn the taper adjustment nut counter-clockwise to increase the pattern width at the brush idler end, and clockwise to decrease the pattern width at the brush idler end. Tighten the mounting bolts.

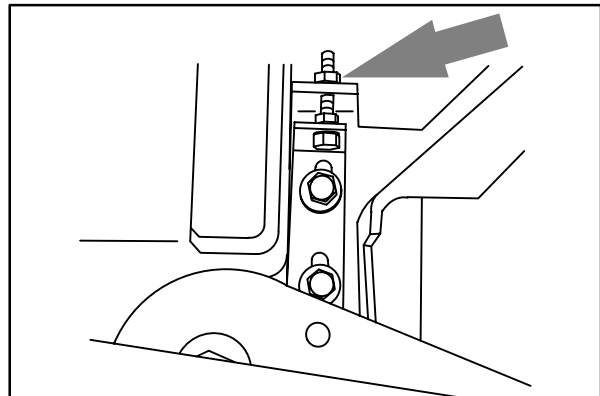

09184

- C. Check the main brush pattern and readjust as necessary. Then adjust the width of the main brush pattern.

SIDE BRUSH

The side brush sweeps debris along edges into the path of the main brush.

Check the brush daily for wear or damage. Remove any string or wire found tangled on the side brush or side brush drive hub.

Check the side brush pattern daily. One-half of the side brush bristles should contact the floor when the brush is in motion. Adjust the side brush pattern by the side brush down pressure knob. Turn the knob counter-clockwise to increase the brush contact with the sweeping surface, and clockwise to decrease the brush contact with the sweeping surface.

The side brush should be replaced when it no longer sweeps effectively for your application. A guideline length is when the remaining bristles measure 50 mm (2 in) in length. You may change the side brush sooner if you are sweeping light litter, or wear the bristles shorter if you are sweeping heavy debris.

REPLACING SIDE BRUSH

1. Empty the debris hopper.
2. Set the machine parking brake.
3. Stop the engine.

FOR SAFETY: Before leaving or servicing machine; stop on level surface, set parking brake, turn off machine and remove key.

4. Remove the side brush retaining pin from the side brush drive shaft by pulling the pin keeper off over the end of the pin.
5. Slide the side brush off the side brush drive shaft.

NOTE: Remove the drive hub and put it on the new brush if one is not installed.

6. Slide the new side brush onto the side brush drive shaft.

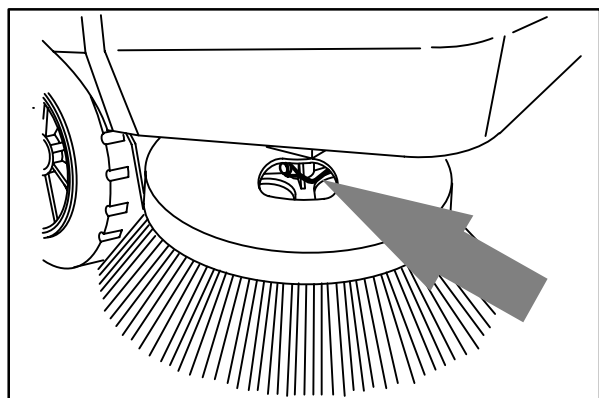

08019

7. Insert the side brush retaining pin through the side brush hub and shaft.
8. Secure the pin by clipping the pin keeper over the end of the pin.
9. Disengage the hopper support bar and lower the hopper.
10. Adjust the side brush pattern with the side brush down pressure knob.

SIDE BRUSH GUARD

Rotate the side brush guard 90° every 200 hours of operation. Replace the brush guard after all four sides have been used.

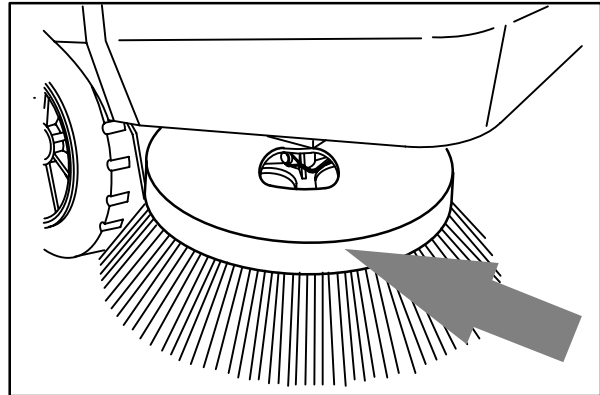

08049

SCRUB BRUSHES

Three disc-type scrub brushes scrub the floor. A spring lock clip holds the scrub brush onto the drive hub.

The scrub brushes should be checked daily for tangled wire or string, wear, and damage. The brushes should be replaced if large portions of the brush bristles are missing or if the remaining brush bristle measure 0.25 in (6 mm) or less in length.

NOTE: Be sure to replace the scrub brushes in sets. Otherwise one scrub brush will be more aggressive than the other.

REPLACING THE SCRUB BRUSHES

1. Set the machine parking brake.
2. Raise the scrub brushes.
3. Stop the engine.

FOR SAFETY: Before leaving or servicing machine; stop on level surface, set parking brake, turn off machine and remove key.

MAINTENANCE

4. Press the brush spring clip ends together with your thumb and index finger to remove the scrub brush. Repeat for the other brushes.
5. Start with the center brush. Slide the new scrub brush under the scrub brush drive assembly.
6. Line up the scrub brush drive socket with the drive plug.
7. Press the brush spring clip together and lift the scrub brush onto the drive plug. Release the spring clip when the brush is in place. Repeat for the other brushes.

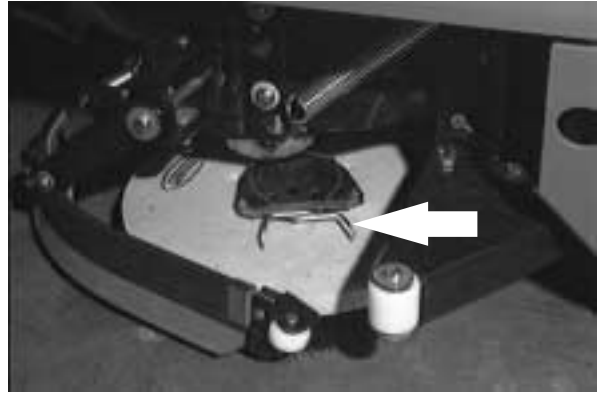

SOLUTION SYSTEM

SOLUTION VALVE

ES™ machines: The solution valve lever has two mounting holes for the solution control linkage. The linkage is mounted to the inside hole at the factory. The linkage can be moved to the middle hole to increase solution flow to the floor. And moved to the outside hole for even greater flow to the floor.

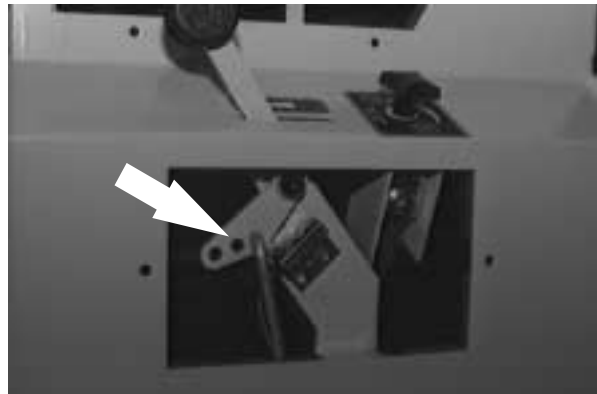

RECOVERY TANK

The recovery tank stores recovered solution. The recovery tank should be drained and cleaned daily, or whenever the float stops the vacuum fan or the recovery tank full light comes on.

NOTE: The water must not be hotter than 55° C (130° F), or tank damage may occur. Do not use steam to clean the tank.

SOLUTION TANK

The solution tank contains the cleaning solution.

The solution tank does not require regular maintenance. If deposits form on the bottom of the tank, rinse the tank with a strong blast of warm water.

NOTE: The water must not be hotter than 55° C (130° F), or tank damage may occur. Do not use steam to clean the tank.

The solution tank on machines with the ES™ option should be drained and cleaned daily.

SQUEEGEES

The squeegee channels water into the vacuum fan suction. The front blade channels the water, and the rear blade wipes the floor.

There are two types of squeegee blades available; one for smooth surfaces is standard on the machine, and one for rough surfaces is an option.

Check the squeegee blades for damage and wear daily. Rotate or replace either of the squeegee blades if the leading edge is torn or worn half-way through the thickness of the blade.

The squeegee can be adjusted for leveling and deflection. The deflection of the squeegee blades should be checked daily, or when scrubbing a different type of floor. The leveling of the squeegee should be checked every 100 hours of machine operation.

LEVELING THE REAR SQUEEGEE

Leveling of the squeegee assures even contact the length of the squeegee blade with the surface being scrubbed. Make sure this adjustment is done on an even, level floor.

1. Lower the squeegee and drive the machine forward.
2. Shut off the engine and set the machine parking brake.

FOR SAFETY: Before leaving or servicing machine; stop on level surface, set parking brake, turn off machine and remove key.

3. Look at the deflection of the squeegee blade over the full length of the squeegee blade.
4. If the deflection is not the same over the full length of the blade, loosen the turnbuckle jam nuts.
5. Turn the turnbuckle clockwise, from the rear of the machine, to increase the deflection at the ends of the squeegee. Turn the turnbuckle counter-clockwise, from the rear of the machine, to decrease the deflection at the ends of the squeegee blade. Be sure to turn both turnbuckles the **same** number of turns.



6. Tighten the jam nuts.

NOTE: When tightening the turnbuckle jam nuts, make sure the rod ends are square with the squeegee frame, not tilted up.

7. Start the engine and drive the machine forward again to check the squeegee blade deflection.
8. Readjust the squeegee blade deflection if necessary.

ADJUSTING REAR SQUEEGEE BLADE DEFLECTION

Deflection is the amount of curl the squeegee blade has when the machine moves forward with the squeegee lowered to the floor. The best deflection is when the squeegee wipes the floor just dry with a minimum amount of deflection.

1. Lower the squeegee and drive the machine forward.
2. Shut off the engine and set the machine parking brake.

FOR SAFETY: Before leaving or servicing machine; stop on level surface, set parking brake, turn off machine and remove key.

3. Look at the deflection of the squeegee blade over the full length of the squeegee blade. The correct amount of deflection is 7 mm (0.25 in).
4. To adjust the amount of deflection, loosen the top knob on the two casters.
5. Turn the bottom knob clockwise to decrease the blade deflection. Turn the bottom knob counter-clockwise to increase the blade deflection. Be sure to turn both knobs the **same** number of turns. Tighten the top knobs on the casters.
6. Start the engine and drive the machine forward again to check the squeegee blade deflection. Readjust the squeegee blade deflection if necessary.
7. Raise the squeegee when finished.

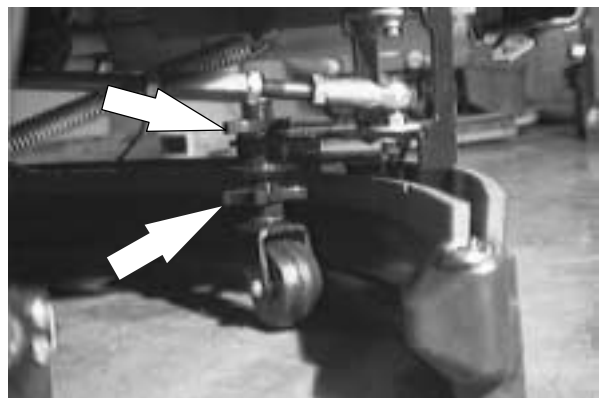

SQUEEGEE BLADES

REAR SQUEEGEE

The rear squeegee has two squeegee blades. Each blade has four wiping edges. To use them all, start with one wiping edge. To use the next wiping edge, rotate the blade end-for-end. To use the next wiping edge, rotate the top edges down, bottom edges up. To use the last edge, rotate the blade end-for-end.

Replace any worn or damaged squeegee blades.

REPLACING OR ROTATING REAR SQUEEGEE BLADES

1. Make sure the squeegee is raised off the floor.
2. Shut the engine off and set the parking brake.

FOR SAFETY: Before leaving or servicing machine; stop on level surface, set parking brake, turn off machine and remove key.

3. Remove the ringed pin, deflector, gasket, retainer bracket, and retainer strip from the end of the squeegee.

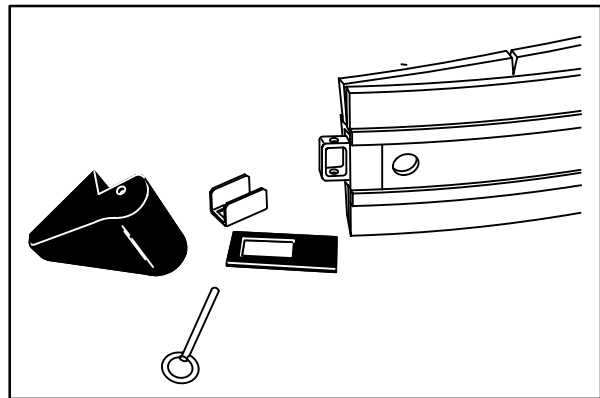

05943

4. Pull the squeegee blade off the squeegee frame.
5. Replace or rotate the squeegee blade to allow a new edge to face the front of the machine.
6. Slide the squeegee blade onto the squeegee frame

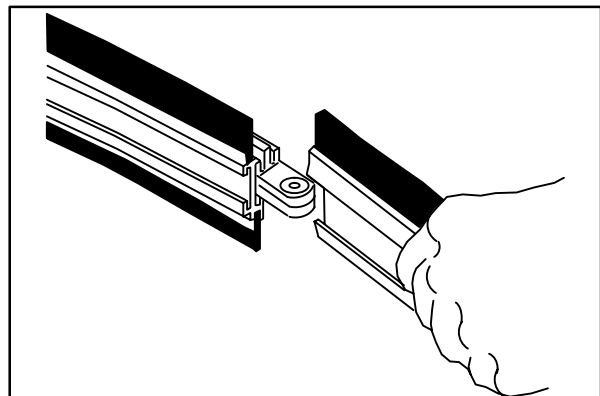

04370

NOTE: Lubricating the squeegee frame where the squeegee blade makes contact with it will make it easier to slide the blade onto the frame.

MAINTENANCE

7. Slip the retainer strip into the squeegee blade.
8. Slip the retainer bracket on the end of the squeegee frame. Place the squeegee gasket on the end of the squeegee frame with the long end down and back.
9. Replace the deflector and the ringed pin.
10. Adjust the squeegee blade leveling and deflection as stated in *LEVELING THE REAR SQUEEGEE* and *ADJUSTING REAR SQUEEGEE BLADE DEFLECTION*.

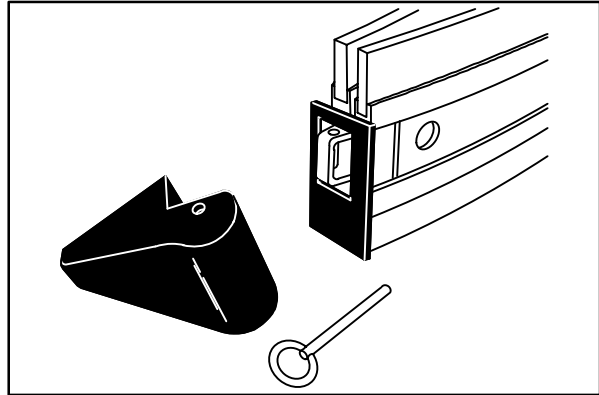

05945

SIDE SQUEEGEES

The side squeegees control water spray and channel water into the path of the rear squeegee. Check the side squeegees for damage and wear daily. Replace the side squeegee blades whenever they become damaged or lose their shape or resilience. Replace the squeegee deflectors whenever they become worn.

REPLACING SIDE SQUEEGEE BLADES

1. Raise the scrub head.
2. Turn off the machine and set the machine parking brake.

FOR SAFETY: Before leaving or servicing machine; stop on level surface, set parking brake, turn off machine and remove key.

3. Remove the cotter pin, clevis pin, deflector, and the retainer bracket from the front of the side squeegee.
4. Pull the squeegee blade off the front of the squeegee frame.
5. Slide the new squeegee blade onto the frame.

NOTE: Lubricating the squeegee frame where the squeegee makes contact will make for easier squeegee installation.

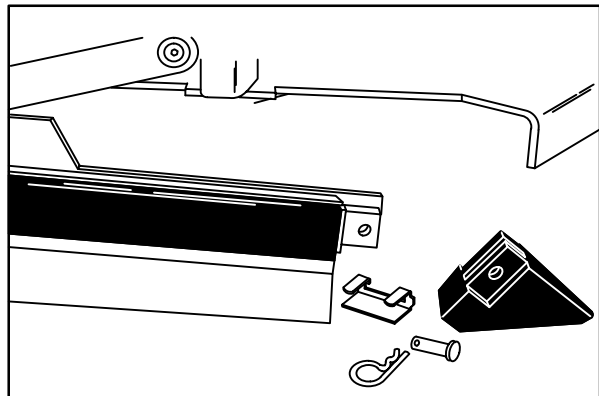

05942

6. Replace the retainer bracket, deflector, clevis pin, and cotter pin.
7. Repeat for the side squeegee on the other side of the scrub head.

SKIRTS AND SEALS

HOPPER LIP SKIRTS

The hopper lip skirts are located on the bottom rear of the hopper. The skirts float over debris and help deflect that debris into the hopper. The hopper lip skirts consist of five bottom lip segments and two additional side lip segments.

Check the hopper lip skirts for wear or damage daily.

Replace the hopper lip skirts when they no longer touch the floor.

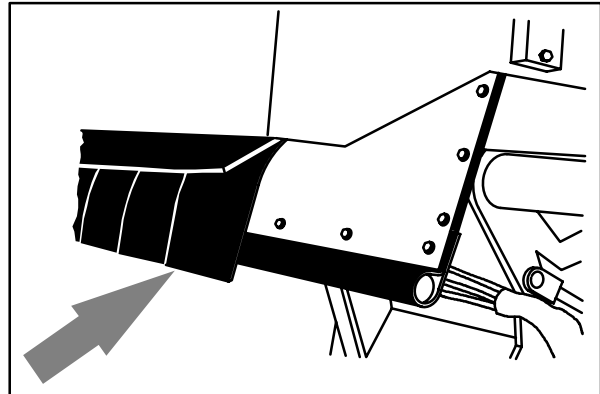

08020

HOPPER SIDE SKIRT

The hopper side skirt is located on the left side of the hopper.

Check the hopper side skirt for wear or damage daily.

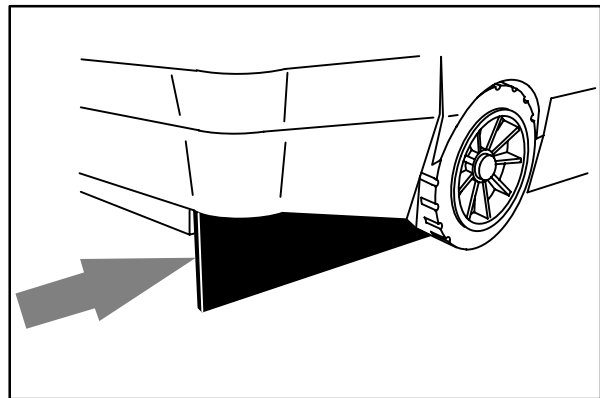

08214

BRUSH DOOR SKIRTS

The brush door skirts are located on the bottom of each of the two main brush doors. The long skirt should clear the floor by 3 to 6 mm (0.12 to 0.25 in). The inner skirt should be angled so that the rear corner touches the floor, and the front corner is 6 mm (0.25 in) above the corner of the long skirt.

Check the skirts for wear or damage and adjustment daily.

NOTE: The brush door skirts have slotted holes to allow for a ground clearance adjustment. The door must be closed for proper adjustment.

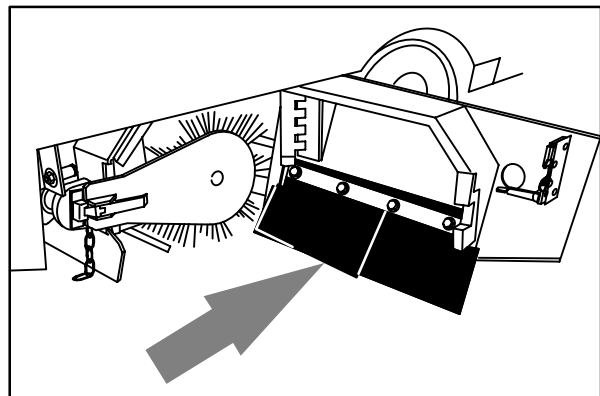

08001

MAINTENANCE

REAR SKIRTS

The two rear skirts are located on the bottom rear of the main brush compartment. The vertical skirt should clear the floor up to 5 mm (0.25 in) in dusty conditions, and touch the floor otherwise. The recirculation skirt is self-adjusting.

Check the skirts for wear or damage and adjustment daily.

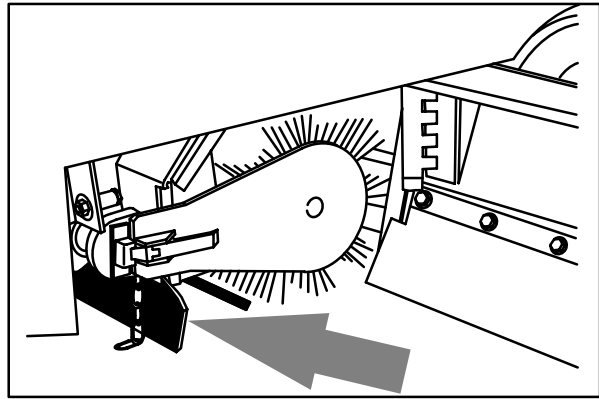

BRUSH DOOR SEALS

The brush door seals are located on both main brush doors and on corresponding portions of the main frame.

Check the seals for wear or damage every 100 hours of operation.

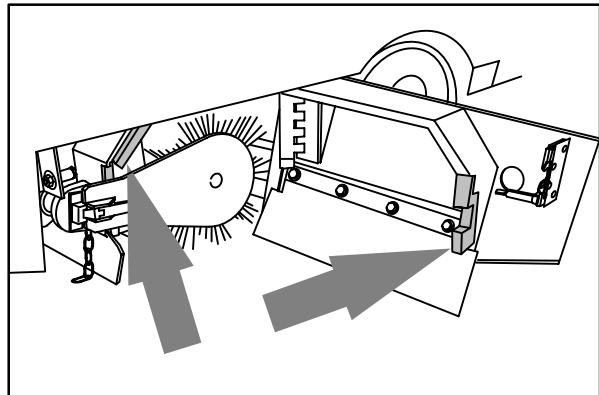

HOPPER SEALS

The hopper seals are located on the top and side portions of the machine frame that contact the hopper.

Check the seals for wear or damage every 100 hours of operation.

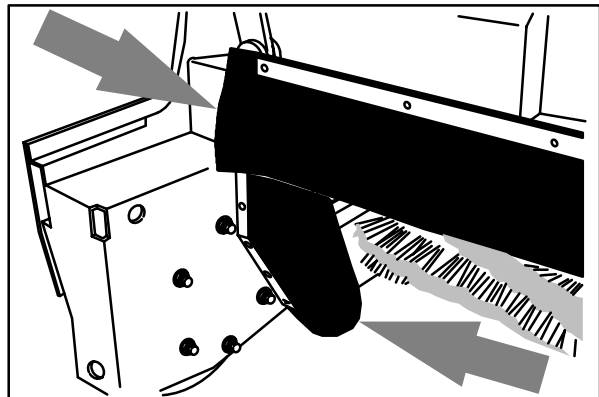

HOPPER INSPECTION DOOR SEAL

The hopper inspection door seal is located on the hopper and seals the front of the debris hopper.

Check the seal for wear or damage every 100 hours of operation.

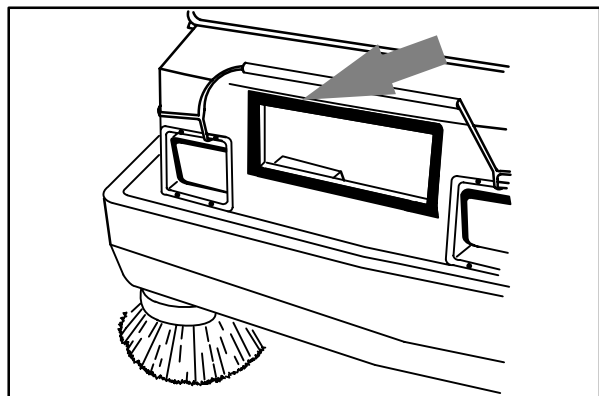

HOPPER DOOR SEALS

The hopper door seals are located on the hopper door. They seal the hopper when the hopper door is closed.

Check the seals for wear or damage every 100 hours of operation.

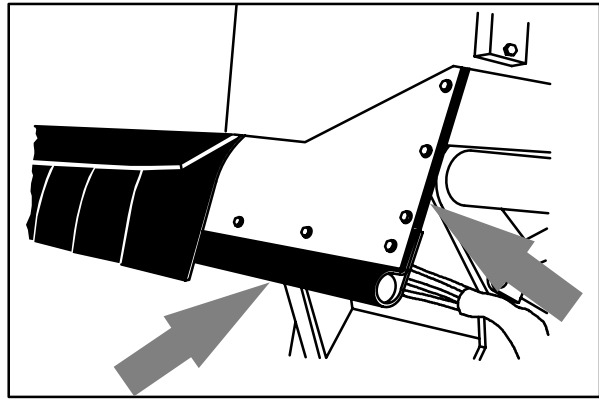

08025

HOPPER COVER SEAL

The hopper cover seal is located on the top edges of the hopper insert. It seals the hopper filter compartment.

Check the seal for wear or damage every 100 hours of operation.

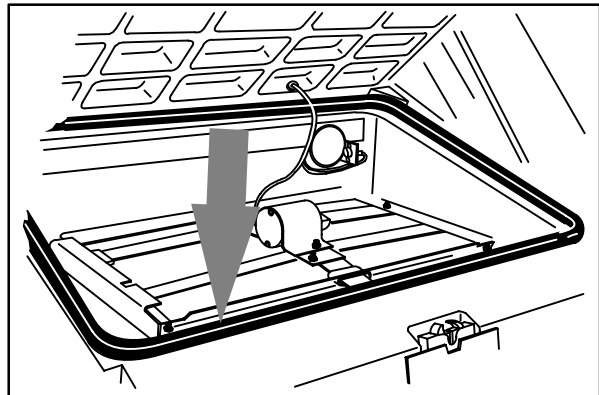

08026

HOPPER DUST SEAL

The hopper dust seal is located under the hopper insert along the top of the hopper.

Check the seal for wear or damage every 100 hours of operation. You can reach the seal by removing the hopper insert.

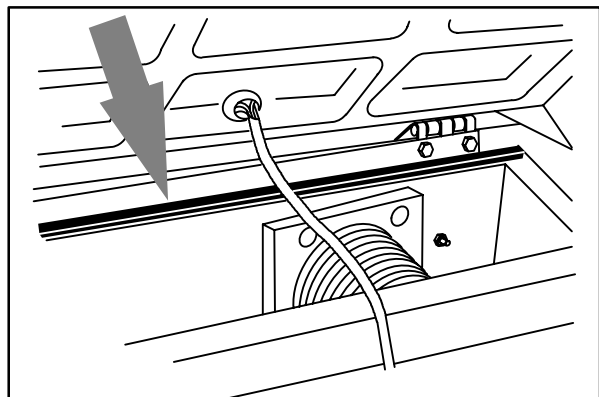

08153

HOPPER VACUUM FAN SEAL

The hopper vacuum fan seal is mounted on the inside of the hopper around the vacuum fan inlet.

Check the seal for wear or damage every 100 hours of operation. You can reach the seal by removing the hopper insert.

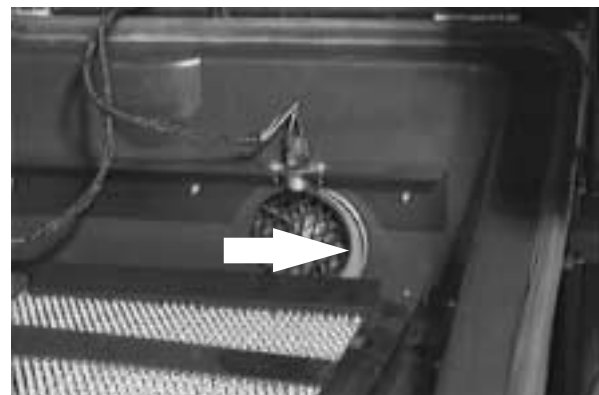

MAINTENANCE

DEMISTER AND COVER SEALS

The demister seals are mounted on the underside of the demister cover. The cover seals are located on the sides of machine where the covers make contact with the machine.

Check the seals for wear or damage every 100 hours of operation

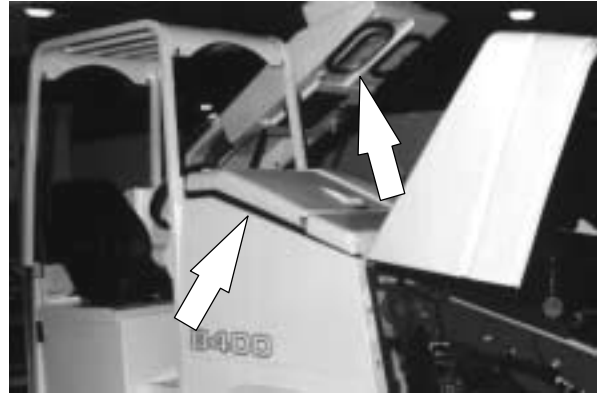

BRAKES AND TIRES

SERVICE BRAKES

The mechanical service brakes are located on the front wheels. The brakes are operated by the foot brake pedal and connecting cables.

Check the brake adjustment every 200 hours of operation.

PARKING BRAKE

The parking brake is set with the parking brake lever that locks the brake pedal.

TIRES

The machine tires are solid. Check the tires every 100 hours of operation for damage.

REAR WHEEL

Torque the rear wheel nuts in a star pattern to 142 to 156 Nm (105 to 115 ft lb) after the first 50-hours of operation, and every 800 hours there after.

PUSHING, TOWING, AND TRANSPORTING THE MACHINE

The propelling pump has a towing valve to prevent damage to the hydraulic system when the machine is being towed. Turn the valve 90° clockwise before towing the machine. Do not exceed 1.6 kph (1 mph) when towing.

You can push the machine from the front or rear, and tow it only from the rear.

The machine has tie-down location on the machine frame for machines that do not have the optional tie-down brackets.

The front tie-down location is the hole in the wheel pocket at front of the machine frame.

The rear tie-down location is the bottom lip at each corner of the rear bumper. Use the lip for hanging tie-down hooks.



WARNING: Hot bumper. Keep away.

When transporting the machine on a trailer or in a truck, be sure to set the parking brake and block the tires to prevent the machine from rolling.

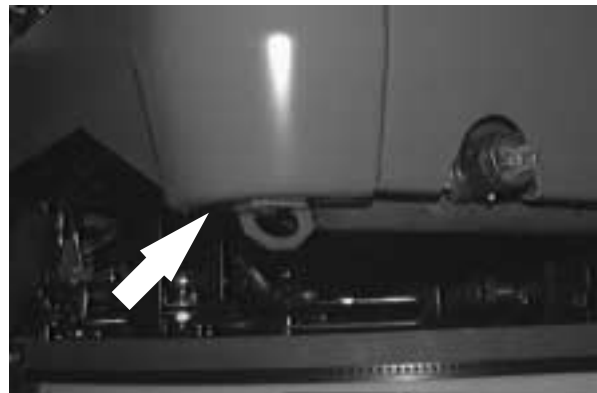

MACHINE JACKING

You can jack up the machine for service at the designated locations. Use a jack of adequate capacity and good working condition. Always stop the machine on a flat, level surface and block the tires before jacking the machine up.

FOR SAFETY: Before leaving or servicing machine; stop on level surface, set parking brake, turn off machine and remove key.

The front jacking locations are on the flat bottom edge of the front of the machine frame next to the front tires.



The rear jacking location is the left corner of the rear bumper.

FOR SAFETY: When servicing machine, block machine tires before jacking machine up.

FOR SAFETY: When servicing machine, jack machine up at designated locations only. Block machine up with jack stands.

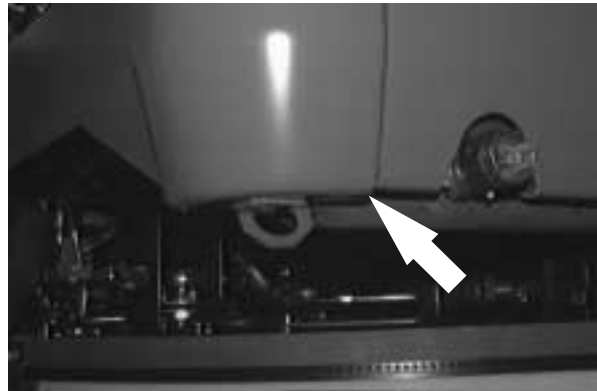

WARNING: Hot bumper. Keep away.

STORING MACHINE

Before storing the machine for an extended period of time, the machine needs to be prepped to lessen the chance of rust, sludge, and other undesirable deposits from forming. Contact Tennant service personnel.

SPECIFICATIONS

GENERAL MACHINE DIMENSIONS/CAPACITIES

Item	Dimension/capacity
Length, Gasoline	2970 mm (117 in)
Length, LPG 15 kg (33 lb) tank	3070 mm (121 in)
Length, LPG 19.5 kg (43 lb) tank	3175 mm (125 in)
Width with side brush	1610 mm (63.5 in)
Height	1625 mm (64 in)
Height with overhead guard	2125 mm (83.7 in)
Track	1330 mm (52.38 in)
Wheelbase	1625 mm (63.88 in)
Main sweeping brush diameter	355 mm (14 in)
Main sweeping brush length	1145 mm (45 in)
Scrub brush diameter	405 mm (16 in)
Side brush diameter	585 mm (23 in)
Sweeping path width	1145 mm (45 in)
Sweeping path width with side brush	1525 mm (60 in)
Squeegee width	1490 mm (58.7 in)
Scrubbing path width	1220 mm (48 in)
Main sweeping brush pattern width	50 to 65 mm (2 to 2.5 in)
Hopper weight capacity	545 kg (1200 lb)
Hopper volume capacity	400 L (14 ft ³)
Dust filter area	6.9 m ² (74 ft ²)
Solution tank	227 L (60 gal)
Recovery tank	227 L (60 gal)
Detergent tank (option)	18.9 L (5 gal)
Total capacity with ES™ (option)	379 L (100 gal)
GVWR	3133 kg (6900 lb)
Ceiling height minimum dumping clearance	2490 mm (98 in)

GENERAL MACHINE PERFORMANCE

Item	Measure
Maximum forward speed	12.9 kmh (8 mph)
Maximum reverse speed	4.8 kmh (3 mph)
Minimum aisle turn width, left	3530 mm (139 in)
Minimum turning radius, right	3235 mm (128 in)
Minimum turning radius, left	2270 mm (90 in)
Maximum rated climb and descent angle	8°

POWER TYPE

Engine	Type	Ignition	Cycle	Aspiration	Cylinders	Bore	Stroke
Ford LSG 2.3	Piston	Breakerless-type spark	4	Natural	4	96 mm (3.78 in)	80 mm (3.126 in)
	Displacement		Net power, governed		Net power, maximum		
	2300 cc (140 cu in)		37.3 kw (50 hp) @ 2400 rpm		47 kw (63 hp) @ 2800 rpm		
	Fuel		Cooling system		Electrical system		
	Gasoline, 87 octane minimum, unleaded. Fuel tank: 37.9 L (10 gal)		Water/ethylene glycol antifreeze		12 V nominal		
	LPG, Fuel tank: 15 kg (33 lb) 19.5 kg (43 lb)		Total: 16.7 L (4.4 gal)		50 A alternator		
			Radiator: 6 L (1.6 gal)				
	Idle speed, no load		(Fast) governed speed, under load		Firing order		
	1450 ± 50 rpm		2400 ± 50 rpm		1–3–4–2		
	Spark plug gap		Valve clearance, cold		Engine lubricating oil with filter		
1 to 1.1 mm (0.042 to 0.046 in)		0.025 to 0.068 mm (0.0010 to 0.0027 in) intake 0.038 to 0.081 mm (0.0015 to 0.0032 in) exhaust		4.7 L (5 qt) 10W30 SAE–SG/SH			

STEERING

Type	Power source	Emergency steering
Rear wheel, hydraulic cylinder and rotary valve controlled	Hydraulic accessory pump	Manual

HYDRAULIC SYSTEM

System	Capacity	Fluid Type
Hydraulic reservoir	37.8 L (10 gal)	TENNANT part no. 65869 – above 7° C (45° F)
Hydraulic total	53 L (14 gal)	TENNANT part no. 65870 – below 7° C (45° F)

BRAKING SYSTEM

Type	Operation
Service brakes	Mechanical drum brakes (2), one per front wheel, cable actuated
Parking brake	Utilize service brakes, cable actuated

TIRES

Location	Type	Size	Pressure
Front (2)	Solid	5 x 18 in	–
Rear (1)	Solid	6 x 18 in	–

INDEX

A

Adjusting rear squeegee deflection, 78
 Air filter, 65
 Cleaning, 65–67
 Dust cap, 65
 Element, 65
 Air filter indicator, 64
 Aisle turn, 87

B

Battery, 67
 Charging system, Light, 17
 Bearings, Front wheel, 60
 Belts, 67
 Engine, 67
 Brake pedal, 14
 Brakes, 28, 84
 Parking, Adjustment, 84
 Service, 84
 System specifications, 88
 Brushes, 33–36, 47, 70–77
 Adjusting main brush taper, 73
 Checking main brush pattern, 72–74
 Checking side brush pattern, 74
 Door latch, 25
 Door seals, 82
 Door skirts, 81
 Main brush, 33, 70–74
 Main brush bristle length, 70
 Main brush down pressure knob, 23
 Main brush II Speed switch, 17
 Main brush normal speed switch, 17
 Replacing main brush, 71–73
 Replacing scrub brushes, 75–77
 Replacing side brush, 74–76
 Scrub brush down pressure knob, 24
 Scrub brush switch, 20
 Scrub brushes, 34, 75–77
 Side brush, 34, 74–76
 Side brush bristle length, 74
 Side brush down pressure knob, 24
 Side brush switch, 16
 Button, Horn, 22

C

Capacities, 87
 Carburetor, 66
 Chains, 67
 Static drag, 67
 Changing LPG fuel tank, 29–31
 Charging system light, 17
 Choke, Engine, 25
 Circuit breakers, 23
 Clogged filter light, 18
 Control panel
 Clogged filter light, 18
 Detergent flow switch, 20
 Edge clean switch, 20
 Engine oil pressure, 17, 18
 Engine speed switch, 21
 Engine water temperature light, 18
 ES switch, 19
 Filter shaker switch, 15
 Fuel level gauge, 19
 Hazard light switch, 15
 Hopper door switch, 16
 Hopper lower switch, 16
 Hopper raise switch, 15
 Hopper temperature light, 18
 Hourmeter, 19
 Main brush II Speed switch, 17
 Main brush normal speed switch, 17
 Operating lights switch, 15
 Recovery tank full light, 19
 Scrub brush switch, 20
 Side brush switch, 16
 Squeegee and vacuum fan switch, 21
 Vacuum fan switch, 16
 Controls, 12
 Brake pedal, 14
 Charging system light, 17
 Circuit breakers, 23
 Clogged filter light, 18
 Detergent flow switch, 20
 Directional pedal, 13
 Edge clean switch, 20
 Engine choke knob, 25
 Engine oil pressure light, 18
 Engine speed switch, 21
 Engine water temperature light, 18
 ES switch, 19
 Filter shaker switch, 15
 Fuel level gauge, 19
 Hazard light switch, 15
 Hopper door switch, 16
 Hopper lower lever, 16
 Hopper raise switch, 15

OPERATION

Hopper temperature light, 18
Horn button, 22
Hourmeter, 19
Ignition switch, 22
Latches, 25
Main brush down pressure knob, 23
Main brush II Speed switch, 17
Main brush normal speed switch, 17
Operating lights switch, 15
Operation, 13–26
Parking brake lever, 14
Parking brake pedal, 14
Recovery tank full light, 19
Scrub brush down pressure knob, 24
Scrub brush switch, 20
Side brush down pressure knob, 24
Side brush switch, 16
Solution flow lever, 24
Squeegee and vacuum fan switch, 21
Steering column tilt lever, 22
Steering wheel, 21
Symbols, 10–12
Turn signal switch, 22
Vacuum fan switch, 16

Covers

Demister, Latch, 25
Hopper, Seals, 83
Recovery tank, Latch, 25
Seals, 84

Crankcase ventilation system, 66

D

Debris hopper, 68–71
Demister, Cover latch, 25
Demister cover, Seals, 84
Detergent flow switch, 20
Dimensions, 87
Directional pedal, 13
Disengaging hopper support bar, 50–52
Distributor, 66
Doors
Brush
Latch, 25
Seals, 82
Skirts, 81
Engine side, Latch, 25
Hopper, Seals, 83
Hopper Inspection, Seal, 82
Hopper, Pivots, 61
Double scrubbing, 42
Draining and cleaning tanks, 43–45

Dust filter, 68–69
Changing, 68–70
Cleaning, 68

E

Edge clean switch, 20
Electrical
Circuit breakers, 23
Ignition switch, 22
Emptying the hopper, 37–39
Engaging hopper support bar, 49–51
Engine, 64–67
Air filter, 65
Cleaning, 65–67
Air filter indicator, 28, 64
Belt, 67
Carburetor, 66
Choke, 25
Coolant temperature, Light, 18
Cooling system, 64
Crankcase ventilation system, 66
Distributor, 66
Fuel filters, 66
Intake manifold, 66
Lubrication, 60
Oil capacity, 60
Oil level, 7, 28
Oil pressure, Light, 18
Side door latch, 25
Spark Plugs, 66
Specifications, 88
Speed switch, 21
Timing belt, 66
Engine choke knob, 25
Engine oil pressure light, 18
Engine speed switch, 21
Engine water temperature light, 18
ES switch, 19

F

Filling the tanks, 38–40
Filter shaker switch, 15
Fuel, 48
Fuel filters, 66
Fuel level, 28
Fuel level gauge, 19
Fuel tank, 8
Changing LPG, 29–31

G

Gauge, Fuel level, 19
Grease fittings, Rear wheel support, 60

H

Hazard light switch, 15
Hopper, 68–71
 Changing dust filter, 68–70
 Clogged filter, Light, 18
 Cover seal, 83
 Disengaging hopper support bar, 50–52
 Door, 16
 Door pivots, 61
 Door seals, 83
 Dust filter, 68–69
 Dust seal, 83
 Engaging hopper support bar, 49–51
 Filter cleaning, 68
 Filter shaker, 15
 Inspection door seal, 82
 Lift arm pivots, 61
 Lip skirts, 81
 Lower, 16
 Raise, 15
 Seals, 82
 Side skirt, 81
 Support bar, 26
 Temperature, Light, 18
 Thermo-sentry, 18, 70
 Vacuum fan seal, 83
Hopper door pivots, 61
Hopper door switch, 16
Hopper lift arm pivots, 61
Hopper lower switch, 16
Hopper raise switch, 15
Hopper support bar, 26
Hopper temperature light, 18
Horn button, 22
Hourmeter, 19
How the machine works, 27
Hydraulic fluid, 62
Hydraulic fluid reservoir, 62
Hydraulic hoses, 63
Hydraulics, 62–64
 Fluid, 62–64
 Fluid filter, 62
 Fluid level, 7, 62
 Hoses, 63
 Propelling motor, 63
 Reservoir, 62

System specifications, 88

I

Ignition switch, 22
Intake manifold, 66

J

Jack points, 86–88

K

Knob, Engine choke, 25
Knobs
 Main brush down pressure, 23
 Scrub brush down pressure, 24
 Side brush down pressure, 24

L

Latches, 25
 Demister cover, 25
 Engine side door, 25
 Main brush doors, 25
 Recovery tank cover, 25
Leveling the rear squeegee, 77–79
Levers
 Parking brake, 14
 Solution flow, 24
 Steering column tilt, 22
Lights
 Charging system, 17
 Clogged filter, 18
 Engine oil pressure, 18
 Engine water temperature, 18
 Hazard light switch, 15
 Hopper temperature, 18
 Operating lights switch, 15
 Recovery tank full light, 19
LPG
 Changing the fuel tank, 29–31
 Service valve, 48
Lubrication, 60–62
 Engine, 60
 Front wheel bearings, 60
 Rear squeegee casters, 61
 Rear wheel support, 60

M

Machine components, 9
Machine jacking, 86–88
Machine leaks, 48
Main brush, 33–34, 70–74
 Adjust brush taper, 73
 Bristle length, 70
 Checking brush pattern, 72–74
 Door latch, 25
 Door seals, 82
 Door skirts, 81
 Down pressure, 23
 II Speed switch, 17
 Maintenance, 70
 Normal speed switch, 17
 Replacing, 71–73
Main brush down pressure knob, 23
Main brush II Speed switch, 17
Main brush normal speed switch, 17
Maintenance, 58–79
 Intervals, 58–60
 Recommended, 8
Maintenance chart, 58–60
Motors, Propelling, 63

O

Operating lights switch, 15
Operation, 7–64
Operation on inclines, 51
Operator Responsibility, 7–8
Operator seat, 26
Options, 52–56
 Detergent flow switch, 20
 ES switch, 19
 Hazard light switch, 15
 Tie-downs, 55
 Turn signal switch, 22
 Vacuum wand, 52–55

P

Parking brake, 84
Parking brake lever, 14
Parking brake pedal, 14
Pedals
 Brake, 14
 Directional, 13
 Parking brake, 14
Post-operation checklist, 47–49

Pre-operation checklist, 27–29
Pushing machine, 85

R

Radiator, 64
 Coolant level, 8, 64
 Coolant type, 64
 Flushing system, 64
 Hoses, 64
Rear squeegee, 79–81
 Deflection, 78
 Leveling, 77–79
 Replacing blades, 79–81
Rear squeegee casters, 61
Rear wheel, 84
Recovery tank, 47, 76
 Cover latch, 25
 Full light, 19
Recovery tank full light, 19
Replacing rear squeegee blades, 79–81
Replacing side squeegee blades, 80

S

Safety
 Disengaging hopper support bar, 50–52
 Engaging hopper support bar, 49–51
 Hopper support bar, 26
 Labels, 5–7
 Precautions, 3–5
Scrub brush down pressure knob, 24
Scrub brush switch, 20
Scrub brushes, 34, 75–77
 Down pressure, 24
 Replacing, 75–77
 Switch, 20
Scrub head, 70
Scrubbing, 40–42
 Double, 42
Scrubbing and brush information, 33–36
Seals, 81–85
 Brush doors, 82
 Demister cover, 84
 Hopper, 82
 Hopper cover, 83
 Hopper door, 83
 Hopper dust, 83
 Hopper inspection door, 82
 Hopper vacuum fan seal, 83

- Seat, 26
 - Adjustment, 26
 - Lift, 26
 - Service records, 48
 - Side brush, 34, 74–76
 - Bristle length, 74
 - Checking brush pattern, 74
 - Down pressure, 24
 - Replacing, 74–76
 - Switch, 16
 - Side brush down pressure knob, 24
 - Side brush guard, 75
 - Side brush switch, 16
 - Side squeegee, Blades, 80
 - Side squeegees, 80
 - Replacing blades, 80
 - Skirts, 47, 81–83
 - Brush doors, 81
 - Hopper Lip, 81
 - Hopper side, 81
 - Rear, 82
 - Solution flow lever, 24
 - Solution system, 76
 - Detergent flow switch, 20
 - ES switch, 19
 - Flow lever, 24
 - Recovery tank, 76
 - Solution tank, 76
 - Solution valve, 76
 - Solution tank, 47, 76
 - Solution valve, 76
 - Spark plugs, 66
 - Specifications, 87–89
 - Braking system, 88
 - Hydraulic system, 88
 - Machine capacities, 87
 - Machine dimensions, 87
 - Machine performance, 87
 - Power type, 88
 - Steering, 88
 - Tires, 88
 - Squeegee and vacuum fan switch, 21
 - Squeegees, 77–79
 - Blades, 79–81
 - Deflection, 29, 47, 78
 - Leveling, 77–79
 - Rear, 79–81
 - Replacing rear blades, 79–81
 - Replacing side blades, 80
 - Side, 80
 - Switch, 21
 - Starting the machine, 31–33
 - Static drag chain, 67
 - Steering, 28
 - Specifications, 88
 - Steering column tilt lever, 22
 - Steering wheel, 21
 - Stop scrubbing, 42
 - Stop sweeping, 36
 - Stop the machine, 45–47
 - Storing machine, 86
 - Sweeping, 35–37
 - Sweeping and brush information, 33–36
 - Switches
 - Detergent flow, 20
 - Edge clean, 20
 - Engine speed, 21
 - ES, 19
 - Filter shaker, 15
 - Hazard light, 15
 - Hopper door, 16
 - Hopper lower, 16
 - Hopper raise, 15
 - Ignition, 22
 - Main brush II Speed switch, 17
 - Main brush normal speed switch, 17
 - Operating lights, 15
 - Scrub brush, 20
 - Side brush, 16
 - Squeegee and vacuum fan, 21
 - Turn signal, 22
 - Vacuum fan, 16
- T**
- Thermo-sentry, 70
 - Thermo-sentry, 18
 - Tie-downs, 55
 - Timing belt, 66
 - Tires, 84
 - Rear wheel, 84
 - Specifications, 88
 - Towing machine, 85
 - Transporting machine, Tie-downs, 55
 - Travel speed, 87
 - Troubleshooting, 56–58
 - Turn signal switch, 22

V

Vacuum fan, Switch, 21

Vacuum fan switch, 16

Vacuum hoses, 47

Vacuum wand, 52–55